

# INSTALLATION INSTRUCTIONS

## StormWall™ XL Curtain Wall

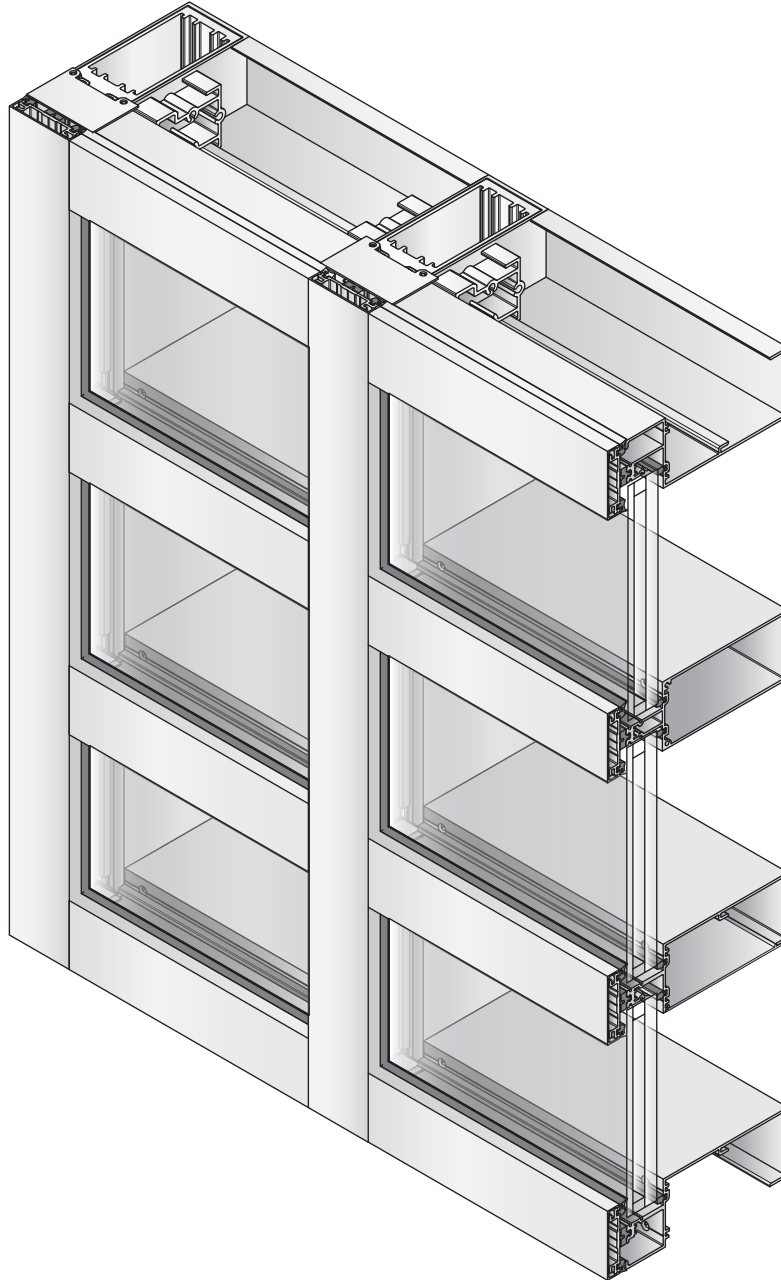

---

Phone: (800) 262-5151 • Fax: (866) 262-3299  
crlaurence.com • usalum.com • crl-arch.com

---

# HANDLING, STORAGE, AND PROTECTION OF ALUMINUM

The following precautions are recommended to protect the material against damage. Following these precautions will help ensure early acceptance of your products and workmanship.

**A. HANDLE CAREFULLY.**

All aluminum materials at job site must be stored in a safe place, well removed from possible damage by other trades. Cardboard wrapped or paper interleaved materials must be kept dry.

**B. CHECK ARRIVING MATERIALS.**

Check for quantities and keep records of where various materials are stored.

**C. KEEP MATERIALS AWAY FROM WATER, MUD, AND SPRAY.**

Prevent cement, plaster or other materials from damaging the finish.

**D. PROTECT THE MATERIALS AFTER ERECTION.**

Protect erected frame with polyethylene or canvas splatter screen. Cement, plaster, terrazzo, other alkaline solutions, and acid based materials used to clean masonry are harmful to the finish. ***If any of these materials come in contact with the aluminum, IMMEDIATELY remove with water and mild soap.***

**IMPORTANT: READ THIS MANUAL THOROUGHLY BEFORE BEGINNING INSTALLATION**

## GENERAL INSTALLATION NOTES

### Recommended Guidelines for All Installations:

- 1. REVIEW CONTRACT DOCUMENTS.** Check shop drawings, installation instructions, architectural drawings, and shipping lists to become thoroughly familiar with the project. The shop drawings take precedence and include specific details for the project. Note any ***field verified*** notes on the shop drawings prior to installing. The installation instructions are of a general nature and cover most conditions.
- 2. INSTALLATION.** All materials are to be installed plumb, level, and true.
- 3. BENCH MARKS.** All work should start from bench marks and/or column lines as established by the architectural drawings and the general contractor with guaranteed accuracy. Working from these datum points and lines determine:
  - a) The plane of the wall in reference to offset lines provided on each floor.
  - b) The finish floor lines in reference to bench marks on the outer building columns.
  - c) Mullion spacing from both ends of masonry opening to prevent dimensional build-up of daylight opening.
- 4. FIELD WELDING.** All field welding must be adequately shielded to avoid any splatter on glass or aluminum. Results will be unsightly and/or structurally unsound. Advise general contractor and other trades accordingly. All field welds of steel anchors must receive touch-up paint (zinc chromate) to avoid rust.
- 5. SURROUNDING CONDITIONS.** Make certain that construction which will receive your materials is in accordance with the contract documents. If not, notify the general contractor in writing and resolve differences before proceeding with work.
- 6. ISOLATION OF ALUMINUM.** Aluminum to be placed in direct contact with uncured masonry or incompatible materials should be isolated with a heavy coat of zinc chromate or bituminous paint.
- 7. SEALANTS.** Sealants must be compatible with all materials with which they have contact, including other sealant surfaces. Consult with sealant manufacturer for recommendations relative to joint size, shelf life, compatibility, cleaning, priming, tooling, adhesion, etc. It is the responsibility of the ***Glazing Contractor*** to submit a statement from the sealant manufacturer indicating that glass and glazing materials have been tested for compatibility and adhesion with glazing sealants, and interpreting test results relative to material performance, including recommendations for primers and substrate preparation required to obtain adhesion. The chemical compatibility of all glazing materials and framing sealants with each other and with like materials used in glass fabrication must be established. This is required on every project.

## GENERAL INSTALLATION NOTES (CONTINUED)

8. **FASTENING.** Within the body of these instructions "fastening" means any method of securing one part to another or to adjacent materials. Only those fasteners used within the system are specified in these instructions. Due to the varying perimeter conditions and performance requirements, perimeter and anchor fasteners are not specified in these instructions. For perimeter and anchor fasteners refer to the shop drawings or consult the fastener supplier.
9. **BUILDING CODES.** Due to the diversity in state/provincial, local, and federal laws and codes that govern the design and application of architectural products, it is the responsibility of the individual architect, owner, and installer to assure that products selected for use on projects comply with all the applicable building codes and laws. U.S. Aluminum exercises no control over the use or application of its products, glazing materials, and operating hardware, and assumes no responsibility thereof.
10. **EXPANSION JOINTS.** Expansion joints and perimeter seals shown in these instructions and in the shop drawings are shown at normal size. Actual dimensions may vary due to perimeter conditions and/or difference in metal temperature between the time of fabrication and the time of installation. Gaps between expansion members should be based on temperature at time of installation.
11. **WATER HOSE TEST.** As soon as a representative amount of the wall has been glazed (500 square feet or 46.5 m<sup>2</sup>) a water hose test should be conducted in accordance with AAMA 501.2 specifications to check the installation. On all jobs the hose test should be repeated every 500 square feet (46.5 m<sup>2</sup>) during the glazing operation.
12. **COORDINATION WITH OTHER TRADES.** Coordinate with the general contractor any sequence with other trades which offset curtain wall installation (i.e. fire proofing, back-up walls, partitions, ceilings, mechanical ducts, converters, etc.)
13. **CARE AND MAINTENANCE.** Final cleaning of exposed aluminum surfaces should be done in accordance with AAMA 609.1 for anodized aluminum and 610.1 for painted aluminum.
14. **SEALANTS.** Check shop drawings, installation instructions, architectural drawings and shipping lists to become thoroughly familiar with all sealants referenced in these instructions, which must be a one part elastomeric acetic or neutral cure silicone and must be applied according to the silicone manufacturer's recommendations.
15. **APPLICATION.** Structural silicone must be applied from the interior, and weather seal from the exterior, after the interior structural silicone has fully cured.
16. **MAXIMUM ALLOWABLE STRESS ON SILICONE.** The maximum allowable size of the glass lite is controlled by the width and depth of the silicone joint combined with the specified design windload (PSF or Pa). The stress on the structural silicone must not exceed 20 PSI (137 KPa) for a 6:1 safety factor. Check Structural Silicone Chart in the Architectural Design Manual for this product series.
17. **ARCHITECT.** It is the responsibility of the architect to secure approval of the system and request from the Glazing Contractor the compatibility and adhesion test reports described below.
18. **GLAZING CONTRACTOR.** It is the responsibility of the glazing contractor to submit a statement from the sealant manufacturer indicating that glass and glazing materials have been tested for compatibility and adhesion with glazing sealants and interpreting test results relative to material performance, including recommendations for primers and substrate preparation required to obtain adhesion. The chemical compatibility of all glazing materials and framing sealants with each other and with like materials used in glass fabrication must be established. This is required on every project.
19. **U.S. ALUMINUM.** It is the responsibility of U.S. Aluminum to supply a system to meet the architect's specifications.

# ORDER OF ASSEMBLY AND INSTALLATION











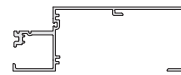
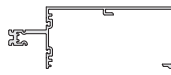





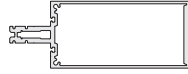



HANDLING, STORAGE, AND PROTECTION OF ALUMINUM.....	2
GENERAL INSTALLATION NOTES.....	2 - 3
PARTS IDENTIFICATION .....	6
FRAME FABRICATION .....	7 - 23
Cutting Guide .....	7
Material Fabrication Guide .....	8
Glass Size Calculation .....	8
90 Degree OS Corner Glass Size Calculation .....	8
Shear Block Hole Guide for Vertical Mullions .....	9
Stacked Horizontal Shear Block Hole Guide for Vertical Mullions .....	10
Shear Block Hole Guide for Corner Mullions .....	11
Stacked Horizontal Shear Block Hole Guide for Corner Mullions .....	11
Steel Reinforcement Options .....	12
Jamb Fabrication .....	13
Vertical Mullion Fabrication .....	14
SSG Mullion Fabrication .....	15
Corner Mullion Fabrication .....	16
Mullion Fabrication for Stacked Horizontal .....	17
Horizontal Member Fabrication .....	18
Stacked Horizontal Fabrication .....	18
Corner Horizontal Fabrication .....	18
Gasket Fabrication for Dry Glaze .....	19
Gasket Fabrication for Wet Glaze and SSG .....	20
Horizontal Pressure Plates .....	21
Vertical Pressure Plates .....	21
Stacked Horizontal Pressure Plates .....	21
Face Cap Fabrication .....	22
Corner Face Cap Fabrication .....	22
Stacked Horizontal Face Cap Fabrication .....	22
9/16" Optional Glazing Adaptor Fabrication .....	23
JAMB AND MULLION INSTALLATION .....	24
HORIZONTAL MEMBER INSTALLATION .....	25
9/16" GLAZING ADAPTOR INSTALLATION .....	26
HORIZONTAL FILLER INSTALLATION .....	27
PERIMETER SEALING .....	28

## ORDER OF ASSEMBLY AND INSTALLATION (CONTINUED)

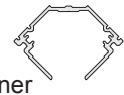



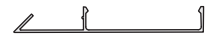







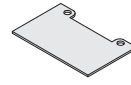
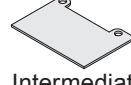
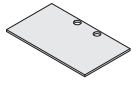

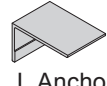
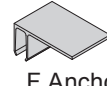
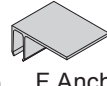
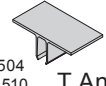
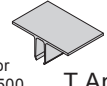

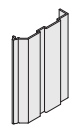
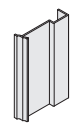
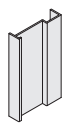



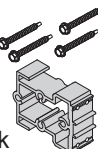
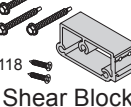
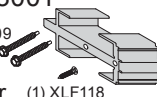





END DAM INSTALLATION .....	29
WATER DEFLECTOR FOR SSG INSTALLATION .....	30
GLAZING GASKET INSTALLATION .....	31
ISOLATOR GASKET INSTALLATION .....	32
GLASS INSTALLATION .....	33
PRESSURE PLATE INSTALLATION .....	34
FACE CAP INSTALLATION .....	35
INTERIOR SEALING FOR WET GLAZED .....	36
90 DEGREE OS CORNER GLASS INSTALLATION .....	37 - 38
Captured Corner .....	37
SSG Corner .....	38
PRESSURE PLATE AND FACE COVER SPLICING (OPTIONAL) .....	39
ENTRANCE DOOR SUBFRAME INSTALLATION .....	40
MID POINT ANCHOR INSTALLATION .....	41
JAMB AND MULLION SPLICE INSTALLATION .....	42
STACKED HORIZONTAL INSTALLATION .....	43

# PARTS IDENTIFICATION

## EXTRUSIONS

<p><b>XL501</b></p>  <p>Head Mullion</p>	<p><b>XL502</b></p>  <p>Sill Mullion</p>	<p><b>XL532</b></p>  <p>Open Back Horizontal</p>	<p><b>XL533</b></p>  <p>Open Back Horizontal</p>	<p><b>XL536</b></p>  <p>Stacked Horizontal</p>	<p><b>XL240</b></p>  <p>90 Degree Corner Mullion</p>
<p><b>XL500</b></p>  <p>Vertical/Horizontal Mullion</p>	<p><b>XL504</b></p>  <p>Structural Glazed Vertical</p>	<p><b>XL510</b></p>  <p>Heavy Vertical Mullion</p>	<p><b>XL122</b></p>  <p>Pocket Filler</p>	<p><b>XL237</b></p>  <p>Horizontal Filler</p>	<p><b>XL224</b></p>  <p>Corner Mullion Cover</p>
<p><b>XLBR15</b></p>  <p>1/2" x 4" x 150" Steel Bar</p>	<p><b>XLBR15</b></p>  <p>4-9/16" x 1-1/4" x 120" Steel U Channel</p>	<p><b>XL162</b></p>  <p>Pressure Plate</p>	<p><b>XL102</b></p>  <p>Pressure Plate for XL536</p>	<p><b>XL132</b></p>  <p>Corner Pressure Plate</p>	<p><b>XL130</b></p>  <p>9/16" Glazing Adaptor</p>
<p><b>XL100</b></p>  <p>Face Cap for XL536</p>	<p><b>XL110</b></p>  <p>Face Cap</p>	<p><b>XL115</b></p>  <p>Corner Face Cap</p>	<p><b>XLF64</b></p>  <p>SSG Corner</p>		

## ACCESSORIES

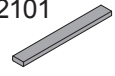
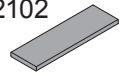
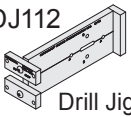
<p><b>XLS20001</b></p>  <p>Anchor Sleeve for XL500</p>	<p><b>XLS20101</b></p>  <p>Anchor Sleeve for XL510 and XL504</p>	<p><b>XLC338</b></p>  <p>Jamb Mullion Cap</p>	<p><b>XLC325</b></p>  <p>Intermediate Mullion Cap</p>	<p><b>XLC358</b></p>  <p>SSG Mullion Cap</p>	<p><b>XLC323</b></p>  <p>90 Degree Corner Cap</p>
<p><b>XLA17401</b></p>  <p>L Anchor for XL500 and XL510</p>	<p><b>XLA10301</b></p>  <p>F Anchor for XL510</p>	<p><b>XLA10302</b></p>  <p>F Anchor for XL500</p>	<p><b>XLA10501</b></p>  <p>T Anchor for XL504 and XL510</p>	<p><b>XLA10502</b></p>  <p>T Anchor for XL500</p>	<p><b>XLA10503</b></p>  <p>T Anchor for XL240</p>
<p><b>XLS19101</b></p>  <p>Splice Sleeve for XL240</p>	<p><b>XLS19401</b></p>  <p>Splice Sleeve for XL500</p>	<p><b>XLS7401</b></p>  <p>Splice Sleeve for XL50</p>	<p><b>XLD350</b></p>  <p>SSG Mullion Water Deflector</p>	<p><b>XLD352</b></p>  <p>End Dam Captured Mullion</p>	<p><b>XLC314</b></p>  <p>90 Degree SSG Corner Cap</p>
<p><b>XLB18301</b></p>  <p>Horizontal Shear Block (4) XLF009 (2) XLF118</p>	<p><b>XLB18401</b></p>  <p>Shear Block for XL536 (3) XLF009 (2) XLF118</p>	<p><b>XLB18001</b></p>  <p>Corner Shear Block (2) XLF009 (1) XLF118</p>	<p><b>XLB18002</b></p>  <p>Corner Shear Block for XL536 (2) XLF009 (1) XLF118</p>	<p><b>XLB18003</b></p>  <p>Corner Shear Block for XL536 (2) XLF009 (1) XLF118</p>	<p><b>XLC312</b></p>  <p>90 Degree Corner Cap</p>
<p><b>XLG117</b></p>  <p>Exterior Gasket</p>	<p><b>XLG160</b></p>  <p>Exterior Bottom Stacked Gasket</p>	<p><b>XLG5185</b></p>  <p>Interior Spacer Gasket</p>	<p><b>XLG1015</b></p>  <p>Dry Glazed Gasket</p>	<p><b>XLG107</b></p>  <p>Isolator Gasket</p>	<p><b>XLR33301</b></p>  <p>Temporary Glazing Retainer</p>
<p><b>XLF325</b></p>  <p>Attach Pressure Plate #12-14 x 1-1/2" HH STS</p>	<p><b>XLF009</b></p>  <p>Attach Shear Block #14 x 1-1/2" HH STS</p>	<p><b>XLF118</b></p>  <p>Secure #10 x 1" FHP STS XLB18301</p>	<p><b>XLF259</b></p>  <p>Attach Steel Tap Plate 1/4-20 PFH Type F</p>	<p><b>XLF320</b></p>  <p>Attach Mullion Cap #10 x 1/2" U-Drive</p>	<p><b>XLF322</b></p>  <p>Attach Jamb Filler #12-14 x 1" HH STS</p>
<p><b>XLF119</b></p>  <p>Attach XL130 #10 x 1-1/2" FHP STS</p>	<p><b>XLSB2101</b></p>  <p>4" Setting Block</p>	<p><b>XLSB2102</b></p>  <p>4" Setting Block</p>	<p><b>DJ112</b></p>  <p>Drill Jig</p>		

## FRAME FABRICATION

### Cutting Guide

Unless otherwise noted, the details shown in these instructions reflect the 7-1/2" system for 1-5/16" glazing.  
NOTE: Structural silicone glazed vertical mullion is referred to as SSG mullion.

Measure ROUGH OPENING to determine FRAME WIDTH and FRAME HEIGHT dimensions. Allow 1/2" (13 mm) minimum clearance for shimming and caulking around perimeter of frame.

Cut material to size per dimensions given below:

#### Frame Members

Verticals:	Frame Height [Rough Opening minus Top and Bottom Joints]
Vertical Pressure Plates:	Frame Height minus 1/4" (6.4)
Vertical Face Covers:	Frame Height (Vertical Covers run through)
Intermediate Horizontals (Tubular):	Daylight Opening (D.L.O.)
Intermediate Horizontals (Rollover):	D.L.O. minus 1/16" (1.6)
Head and Sill:	D.L.O. minus 1/16" (1.6)
Horizontal Pressure Plates:	D.L.O. minus 1/4" (6.4)
Horizontal Face Covers:	D.L.O. minus 1/16" (1.6)
Horizontal Interior Trim (For Rollover):	D.L.O. minus 1/16" (1.6)

#### Glazing Gaskets

Wet Glazed Exterior Glazing Gasket:	Pressure Plate Length plus 1/4" (6.4) longer per foot (304.8)*
Wet Glazed Interior Vertical Glazing Gasket:	D.L.O. plus 1" (25.4) plus 1/4" (6.4) longer per foot (304.8)*
Wet Glazed Interior Horizontal Glazing Gasket:	D.L.O. plus 1/4" (6.4) longer per foot (304.8)*
Vertical Silicone Spacer Gaskets:	D.L.O. plus 1" (25.4) plus 1/4" (6.4) longer per foot (304.8)*
Horizontal Silicone Spacer Gaskets:	D.L.O. plus 1/4" (6.4) longer per foot (304.8)*
Dry Glazed Exterior Glazing Gasket:	Pressure Plate Length plus 1/4" (6.4) longer per foot (304.8)*
Dry Glazed Interior Vertical Glazing Gasket:	D.L.O. plus 1-1/2" (38.1)
Dry Glazed Interior Horizontal Glazing Gasket:	D.L.O. plus 3/16" (4.8)

#### Other Members (As Required)

Horizontal Glazing Adaptors:	D.L.O. minus 1/32" (.8)
Vertical Glazing Adaptors:	D.L.O. plus 1" (25.4)
Door Subframe Jamb:	Door Opening plus 1" (25.4)
Door Subframe Header:	Door Opening minus 1/32" (.8)
Flush Door Jamb Pressure Plate:	Door Opening plus 3/4" (19.1)
Flush Door Header Pressure Plate:	Door Opening minus 1/16" (1.6)
Flush Door Jamb Face Cover:	Door Opening plus 2-1/2" (63.5)
Flush Door Header Face Cover:	Door Opening minus 1/16" (1.6)

\*NOTE: Set Gaskets aside and lay flat until ready to glaze.

# FRAME FABRICATION (CONTINUED)

## Material Fabrication Guide

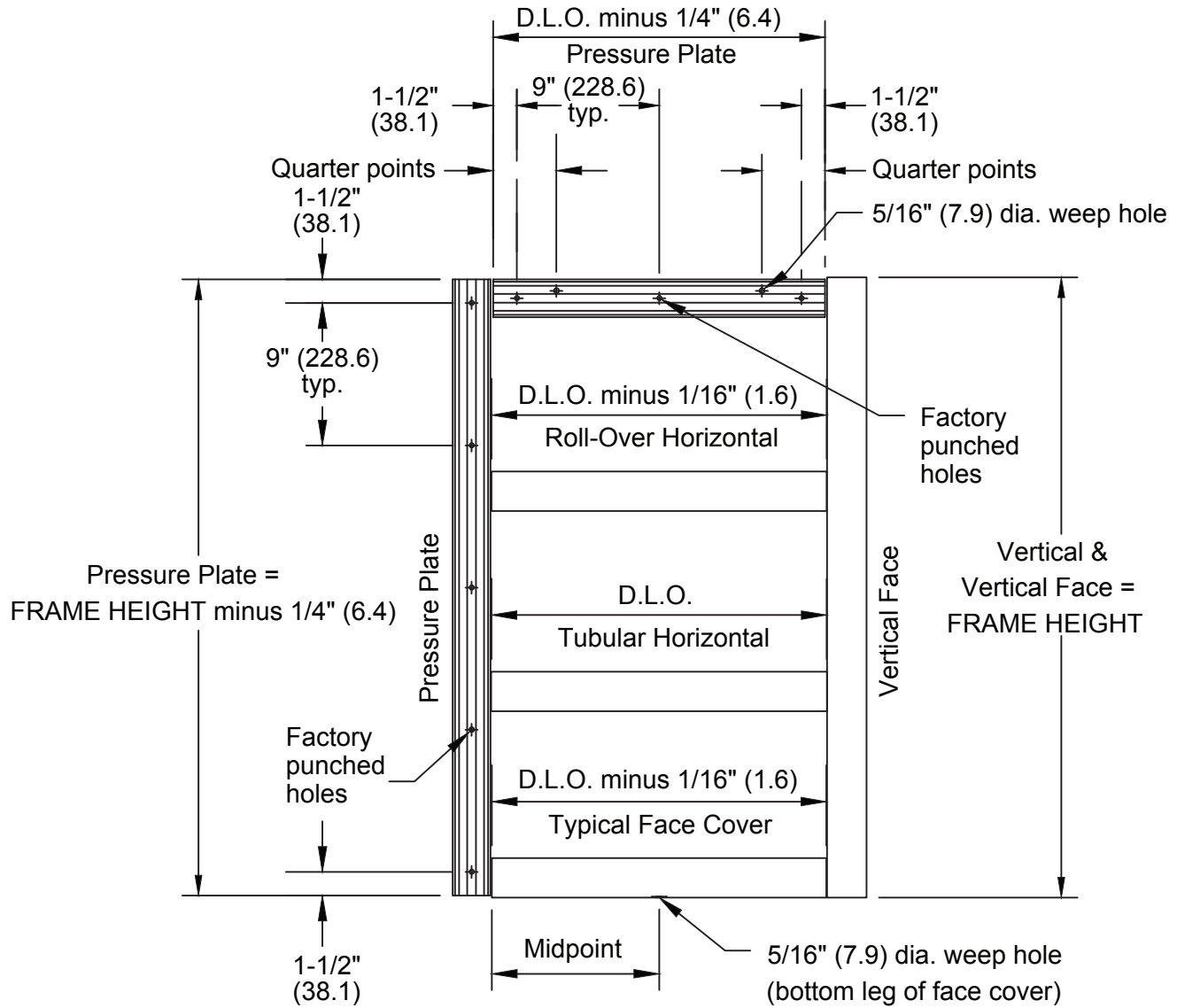

### Glass Size Calculation

CAPTURED = D.L.O. PLUS  $1-1/2" (38.1)$  WIDTH AND HEIGHT

SSG MULLION = D.L.O. PLUS  $2" (50.8)$  WIDTH ONLY

SSG MULLION AND CAPTURED JAMB = D.L.O. PLUS  $1-3/4" (44.5)$  WIDTH ONLY

### 90 Degree OS Corner Glass Size Calculation

CAPTURED CORNER GLASS = D.L.O. PLUS  $1-1/2" (38.1)$  WIDTH AND HEIGHT

SSG CORNER GLASS = D.L.O. PLUS  $1-1/2" (38.1)$  WIDTH AND HEIGHT



# FRAME FABRICATION (CONTINUED)

## Shear Block Hole Guide for Vertical Mullions

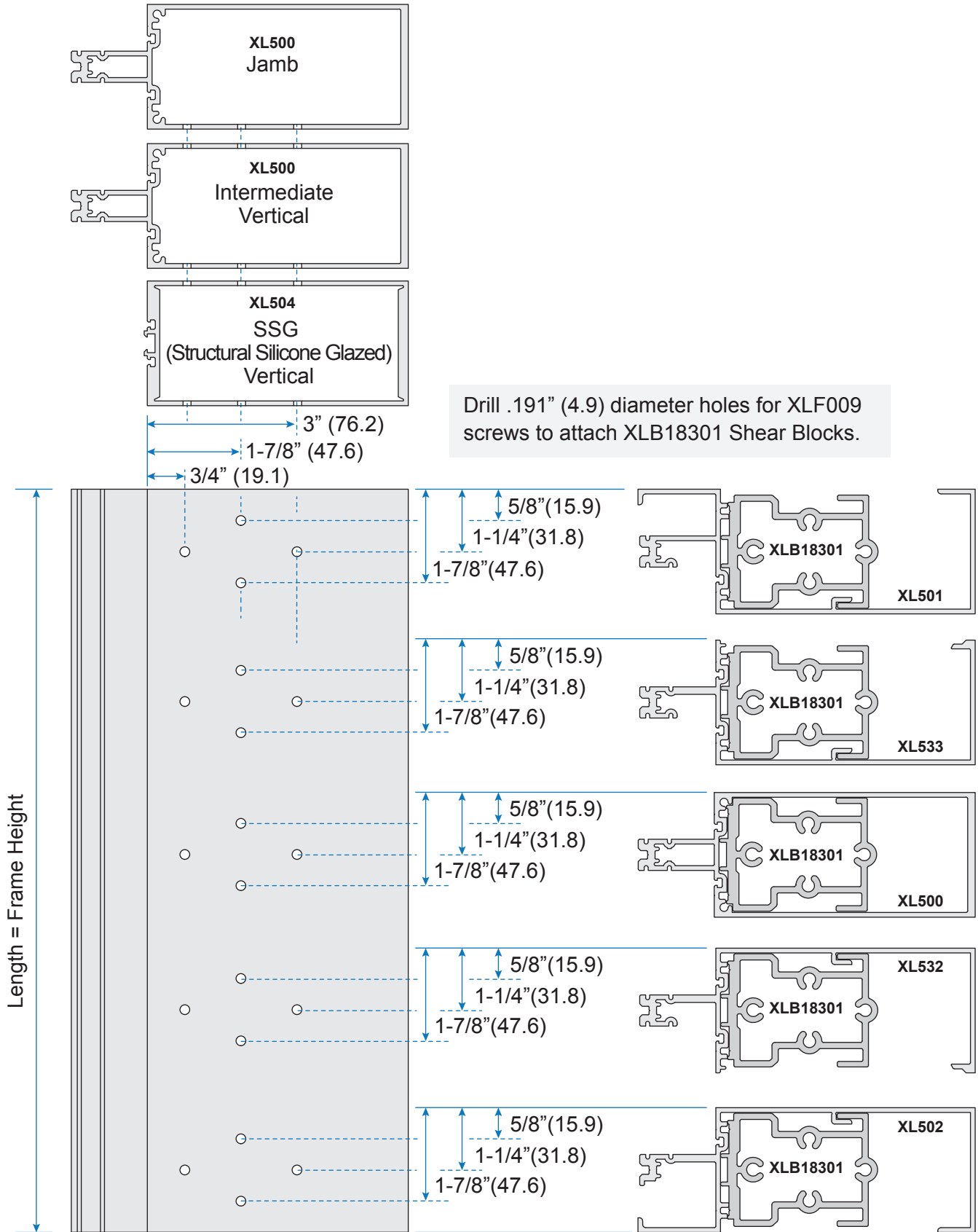

# FRAME FABRICATION (CONTINUED)

## Stacked Horizontal Shear Block Hole Guide for Vertical Mullions

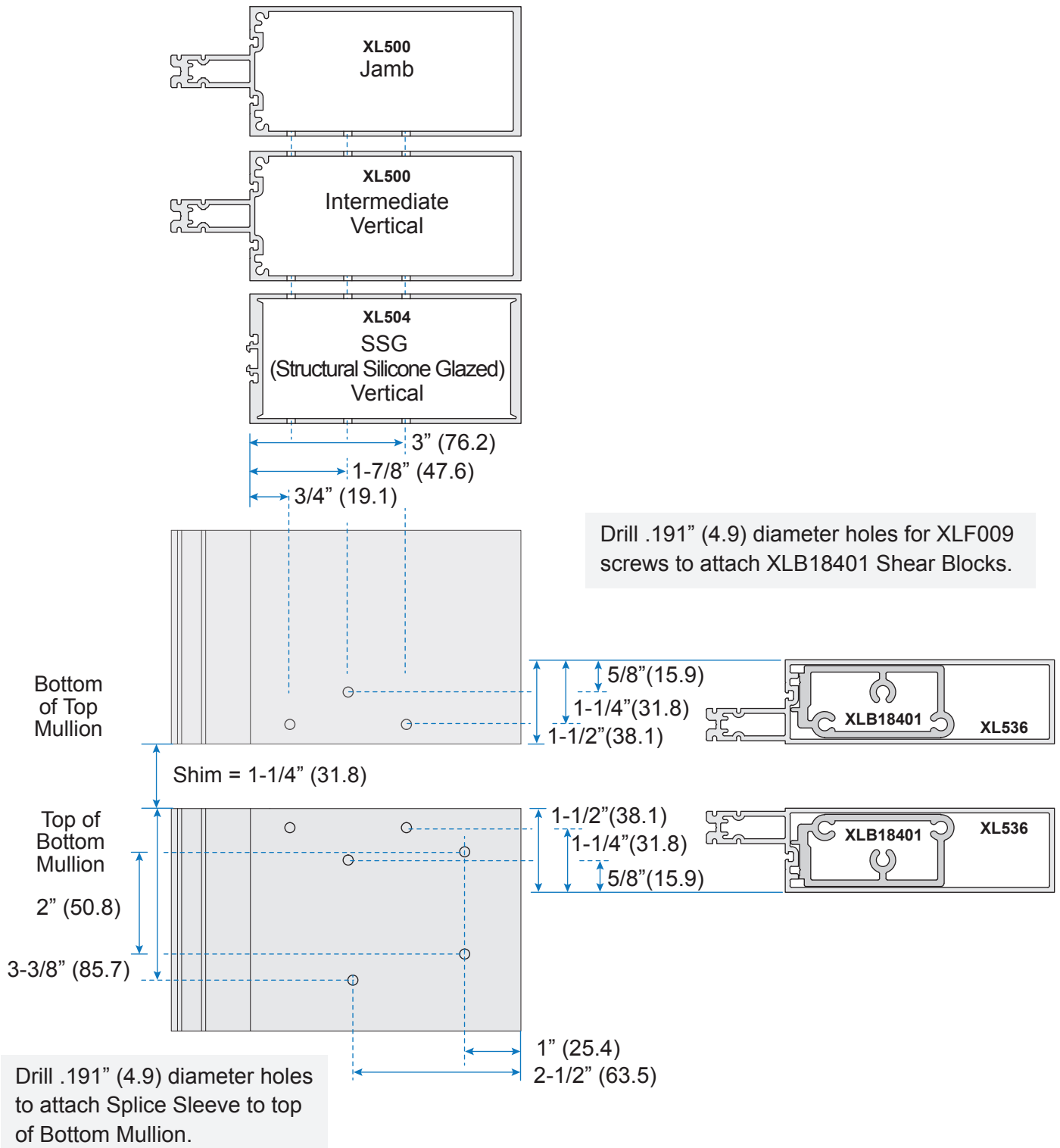

# FRAME FABRICATION (CONTINUED)

## Shear Block Hole Guide for Corner Mullions

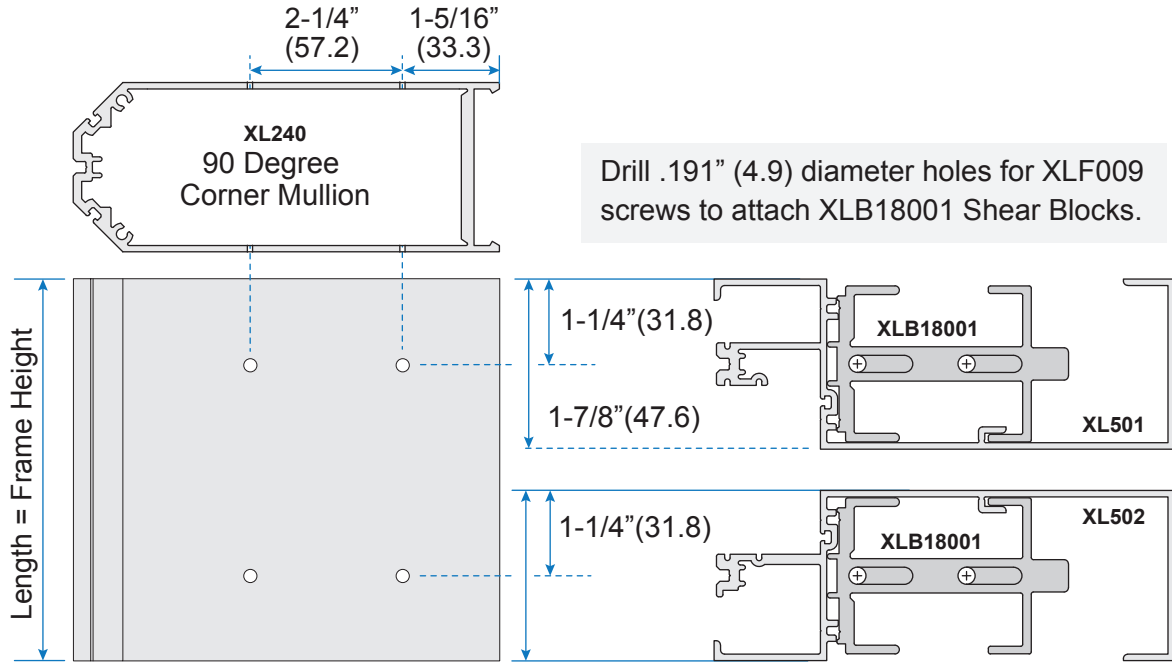

NOTE: Shear Blocks cut at 45 degree angle. Other Horizontals similar.

## Stacked Horizontal Shear Block Hole Guide for Corner Mullions

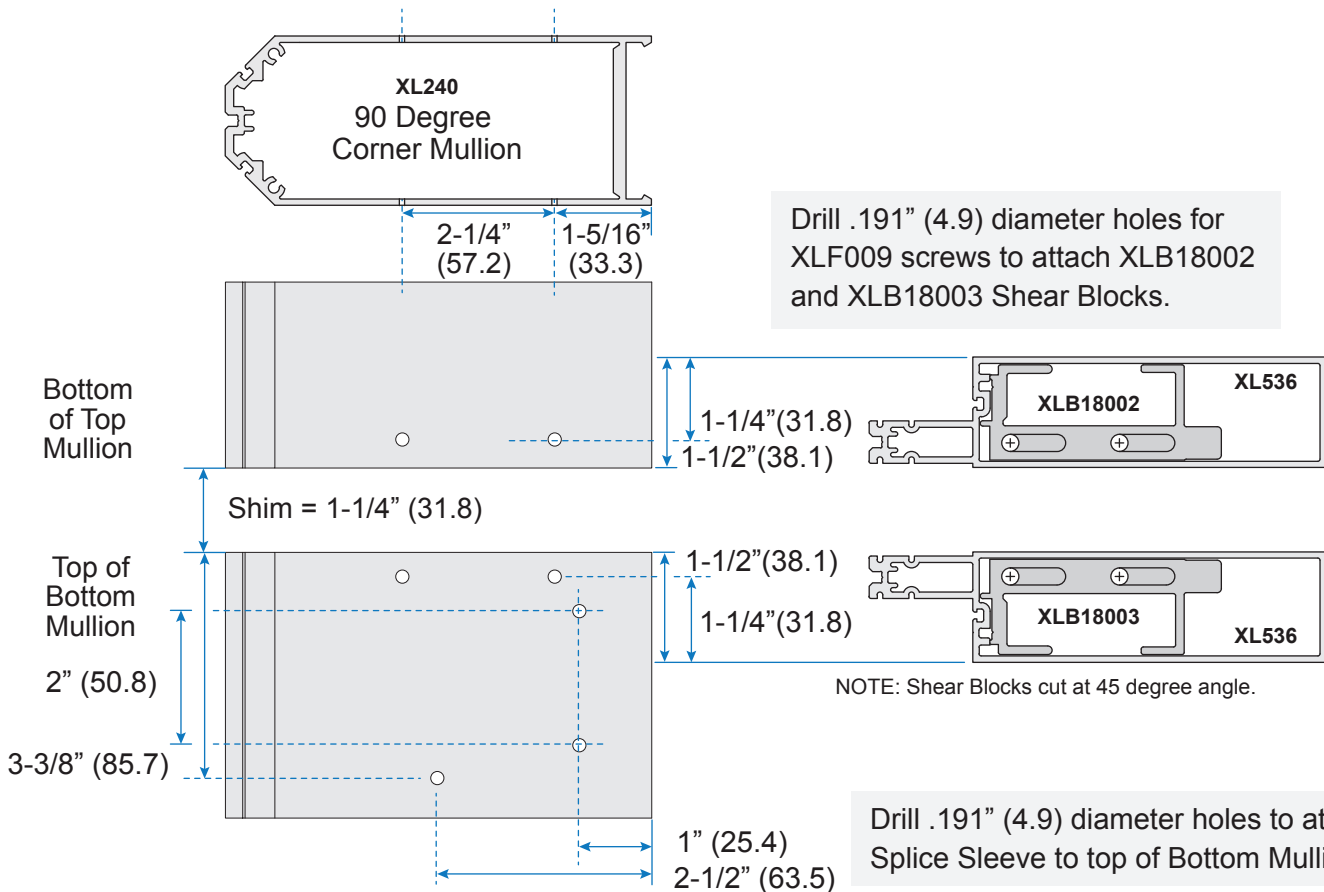

NOTE: Shear Blocks cut at 45 degree angle.

# FRAME FABRICATION (CONTINUED)

## Steel Reinforcement Options

NOTE: Anchor Sleeve required for design pressures above 70 psf. only.

Insert XLS20001 Anchor Sleeve at Mullion ends and match drill with #11 drill bit at Shear Blocks. Secure when installing Shear Blocks.

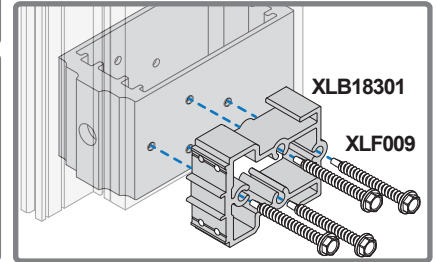
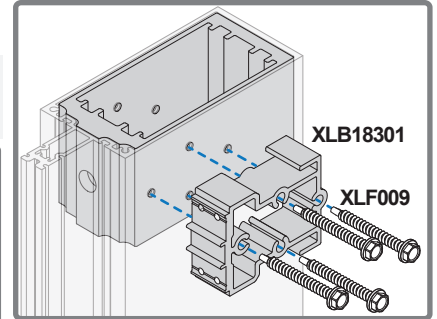
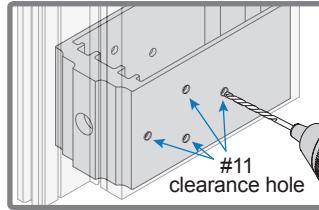
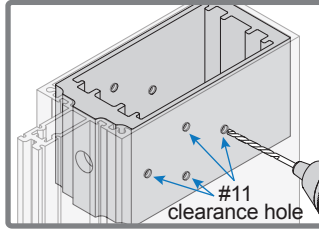
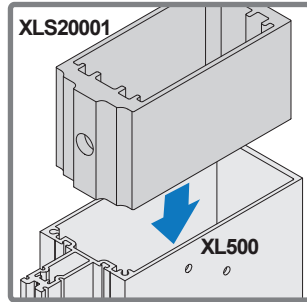
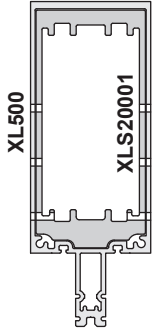

Match drill holes on XLS20001 Anchor Sleeves and attach to ends of XLBR15 Steel Bar. Insert into Mullion and secure when installing Shear Blocks.

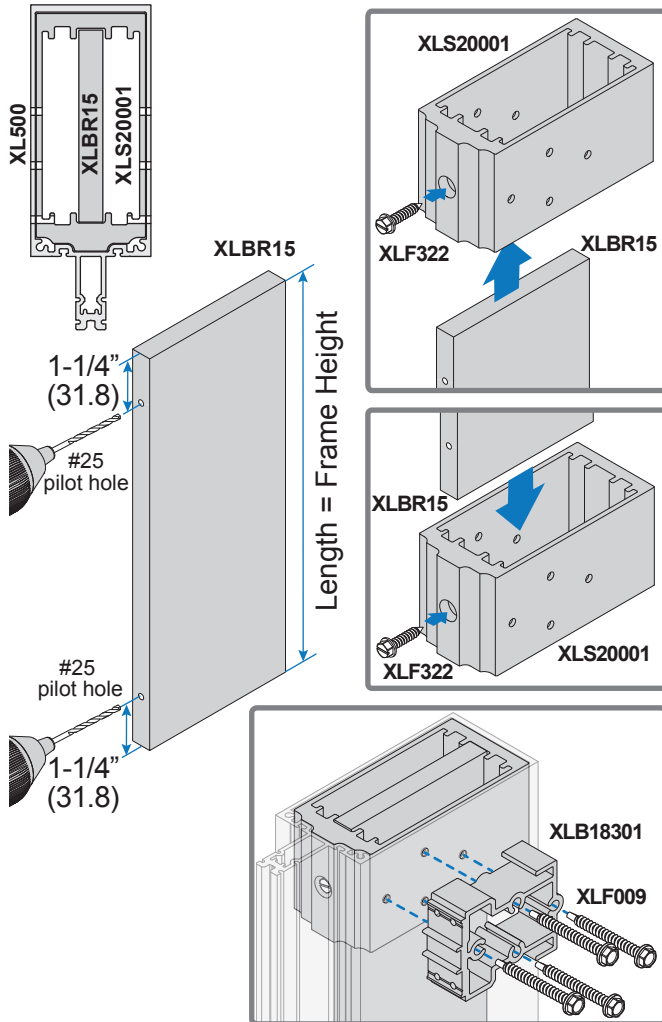

Insert XLBR25 Steel U-Channel in Mullion. Drill clearance holes at Shear Blocks and attach. Match drill holes on XLS20001 Anchor Sleeves and install at Mullion ends.

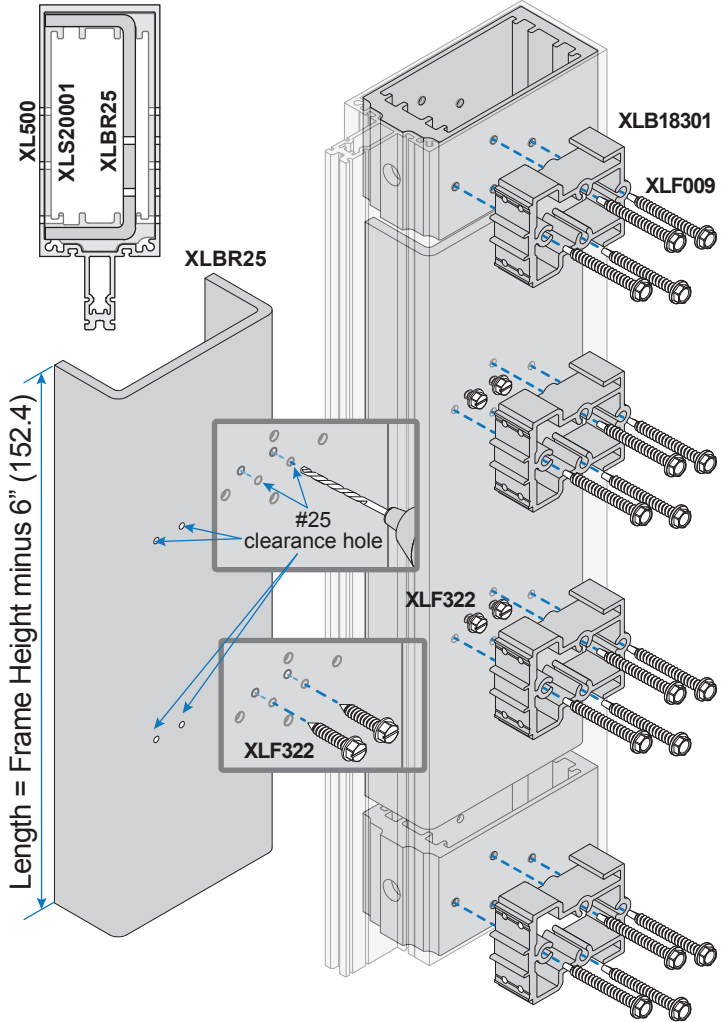

# FRAME FABRICATION (CONTINUED)

## Jamb Fabrication

NOTE: Anchor Sleeve required for design pressures above 70 psf. only.

- ① Insert XLS20001 Anchor Sleeve at Jamb ends and match drill .191" (4.9) diameter holes at Shear Blocks. Secure when installing Shear Blocks.
- ② Attach XLB18301 Shear Blocks using XLF009 Screws.
- ③ Drill .191" (4.9) clear holes 12" (304.8) on center in XL122 Pocket Filler and match drill .1495" (3.8) pilot holes in Jamb.
- ④ Apply bed of Cat. No. 795 Silicone Sealant to Jamb and attach Pocket Filler with XLF322 Screws.

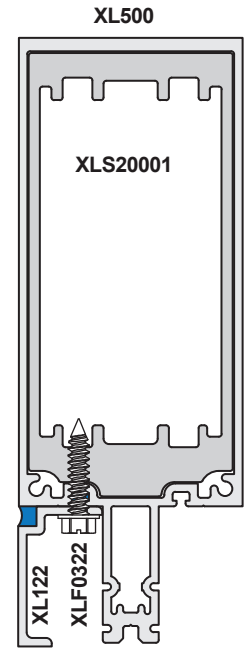
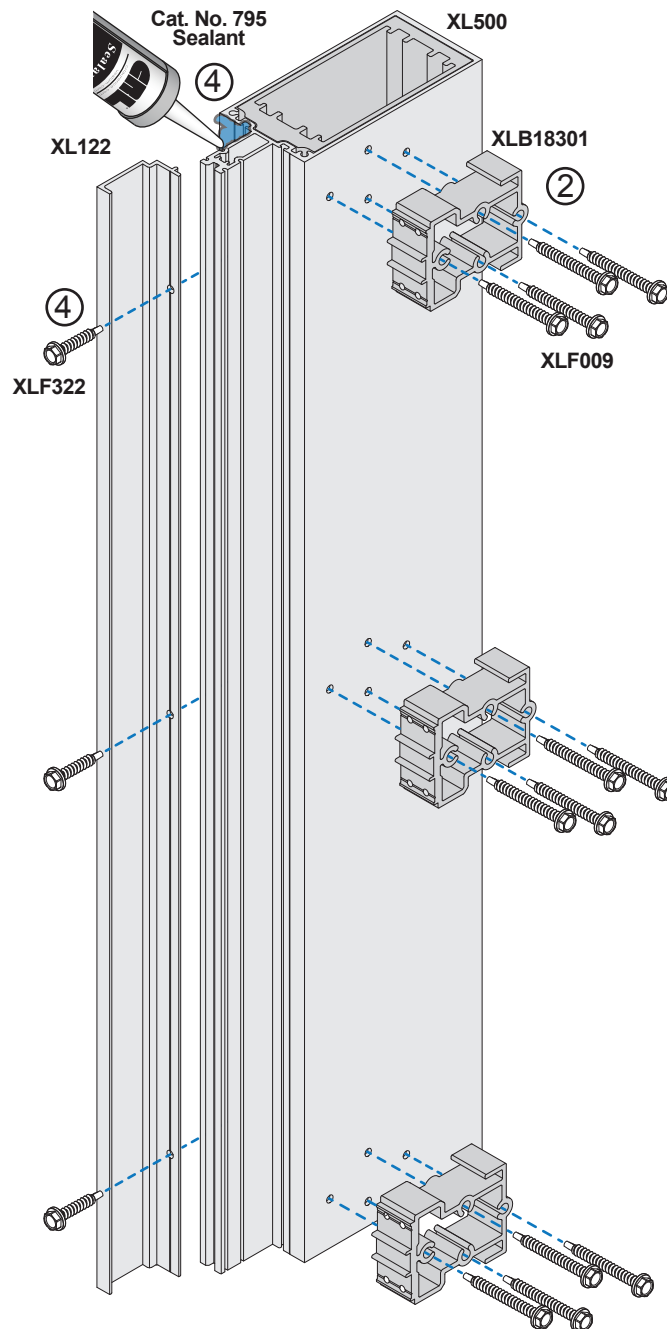
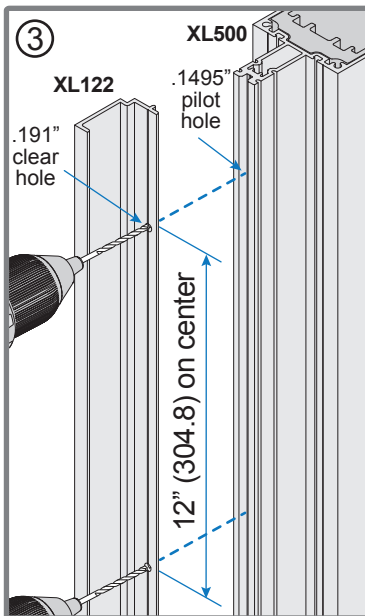
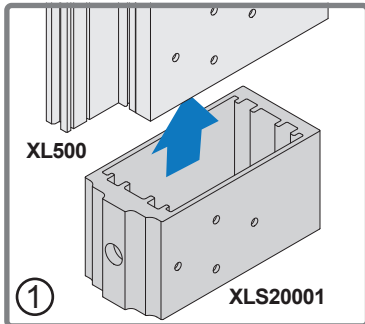
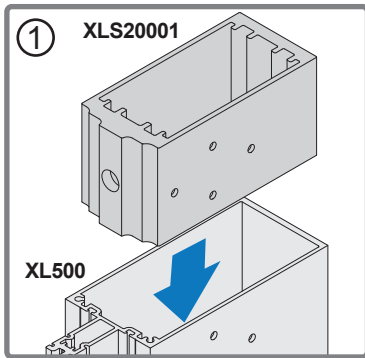

## FRAME FABRICATION (CONTINUED)

### Vertical Mullion Fabrication

NOTE: Anchor Sleeve required for design pressures above 70 psf. only.

- ① Insert XLS20001 Anchor Sleeve at Mullion ends and match drill .191" (4.9) diameter holes at Shear Blocks. Secure when installing Shear Blocks.
- ② Attach XLB18301 Shear Blocks using XLF009 Screws.

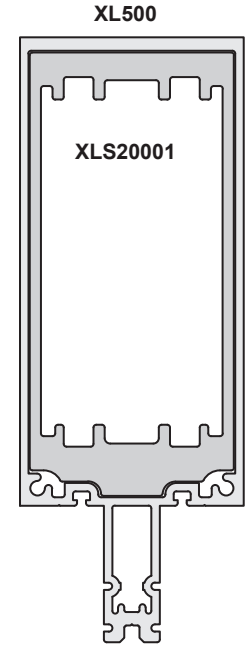
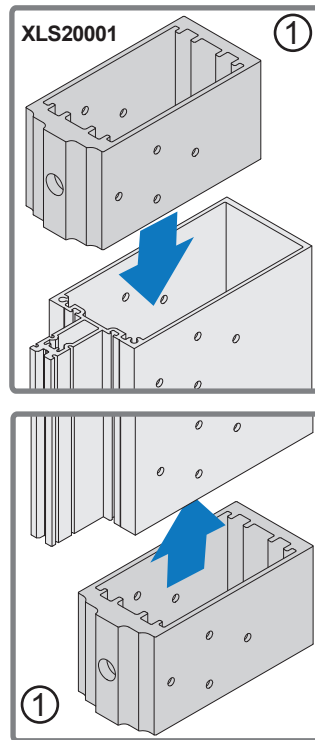
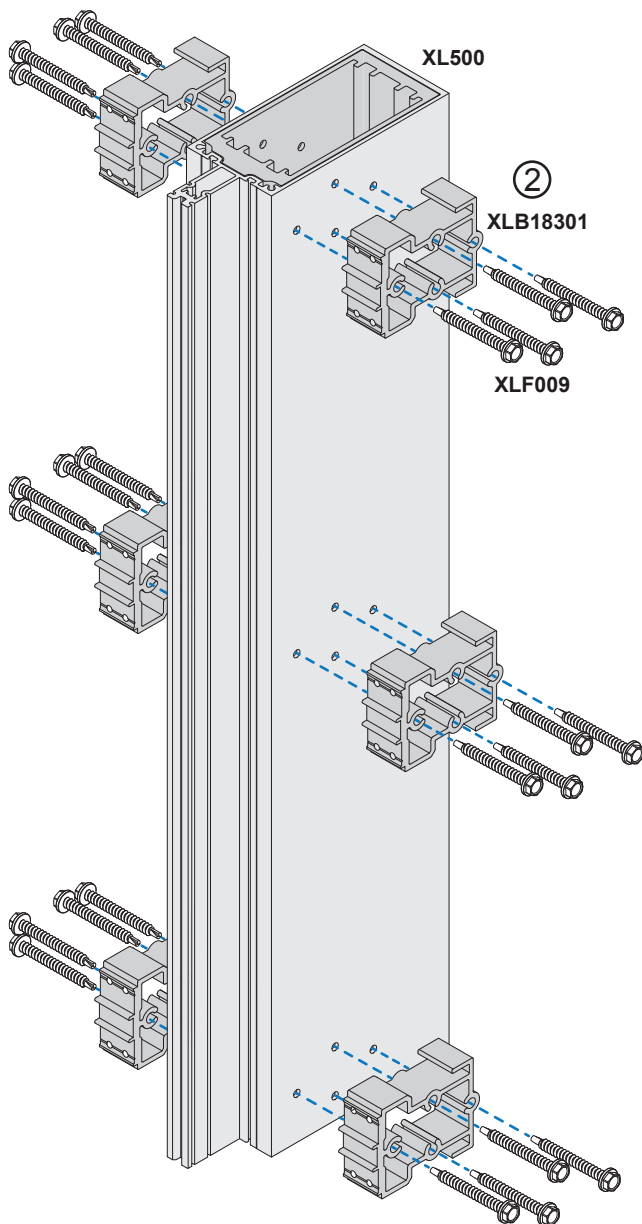

# FRAME FABRICATION (CONTINUED)

## SSG Mullion Fabrication

NOTE: Anchor Sleeve required for design pressures above 70 psf. only.

- ① Insert XLS20101 Anchor Sleeve at Mullion ends and match drill .191" (4.9) diameter holes at Shear Blocks. Secure when installing Shear Blocks.
- ② Attach XLB18301 Shear Blocks using XLF009 Screws.

XL504

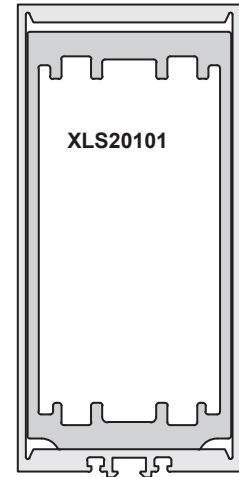

XLS20101

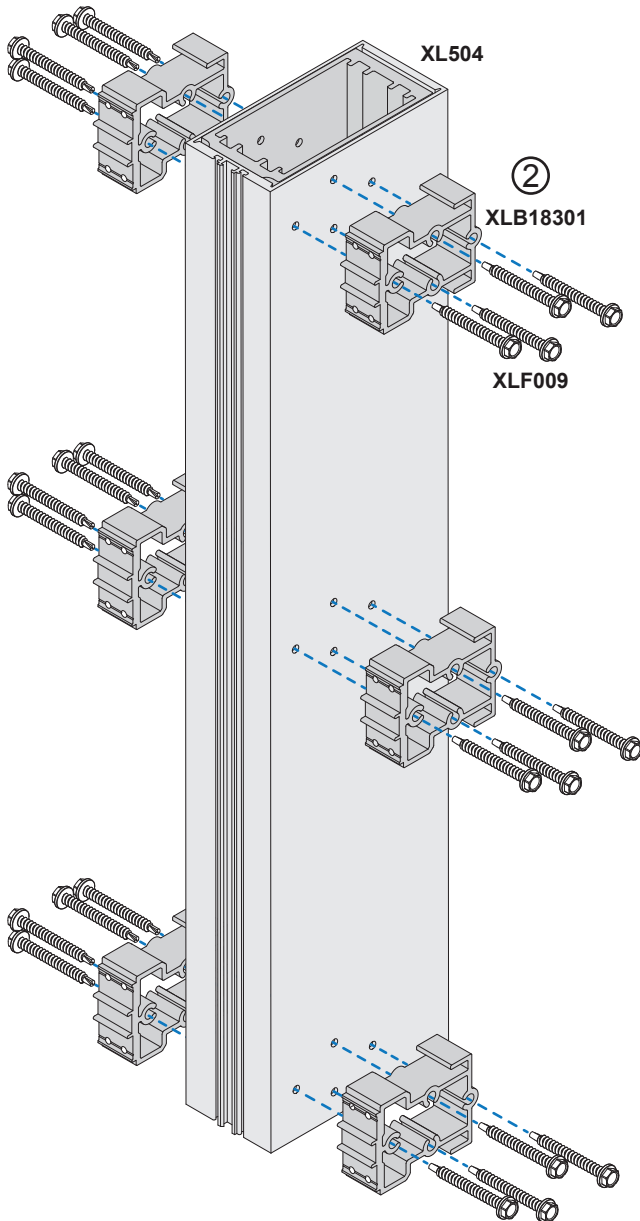
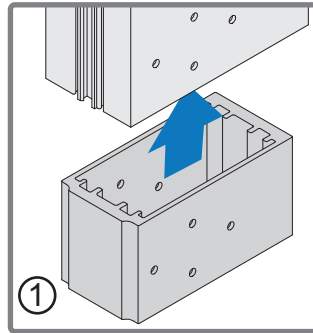
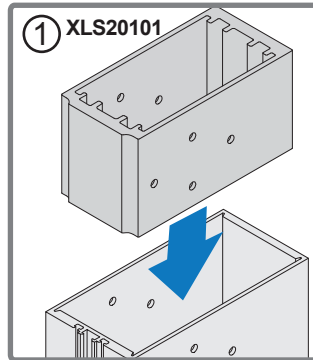

NOTE: For installations calling for Steel Reinforcement, follow instructions on Page 10 using XLS20101 Anchor Sleeve with XL504 SSG Mullion.

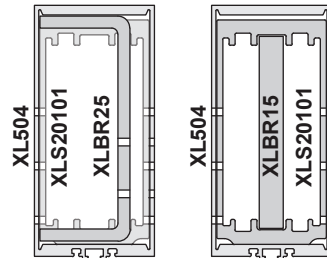

# FRAME FABRICATION (CONTINUED)

## Corner Mullion Fabrication

NOTE: Anchor Sleeve required for design pressures above 70 psf. only.

- ① Insert XLS20001 Anchor Sleeve at Jamb ends and match drill .191" (4.9) diameter holes at Shear Blocks. Secure when installing Shear Blocks.
- ② Attach XLB18001 Shear Blocks using XLF009 Screws.
- ③ Drill .191" (4.9) clear holes 9" (228.6) on center in XL132 Corner Pressure Bar and match drill .1495" (3.8) pilot holes in Corner. Install with XLF325 screws.

NOTE: For SSG Installation XL132 Pressure Bar is removed after glazing.

- ④ Snap XL224 90 Degree Corner Cover into Corner.

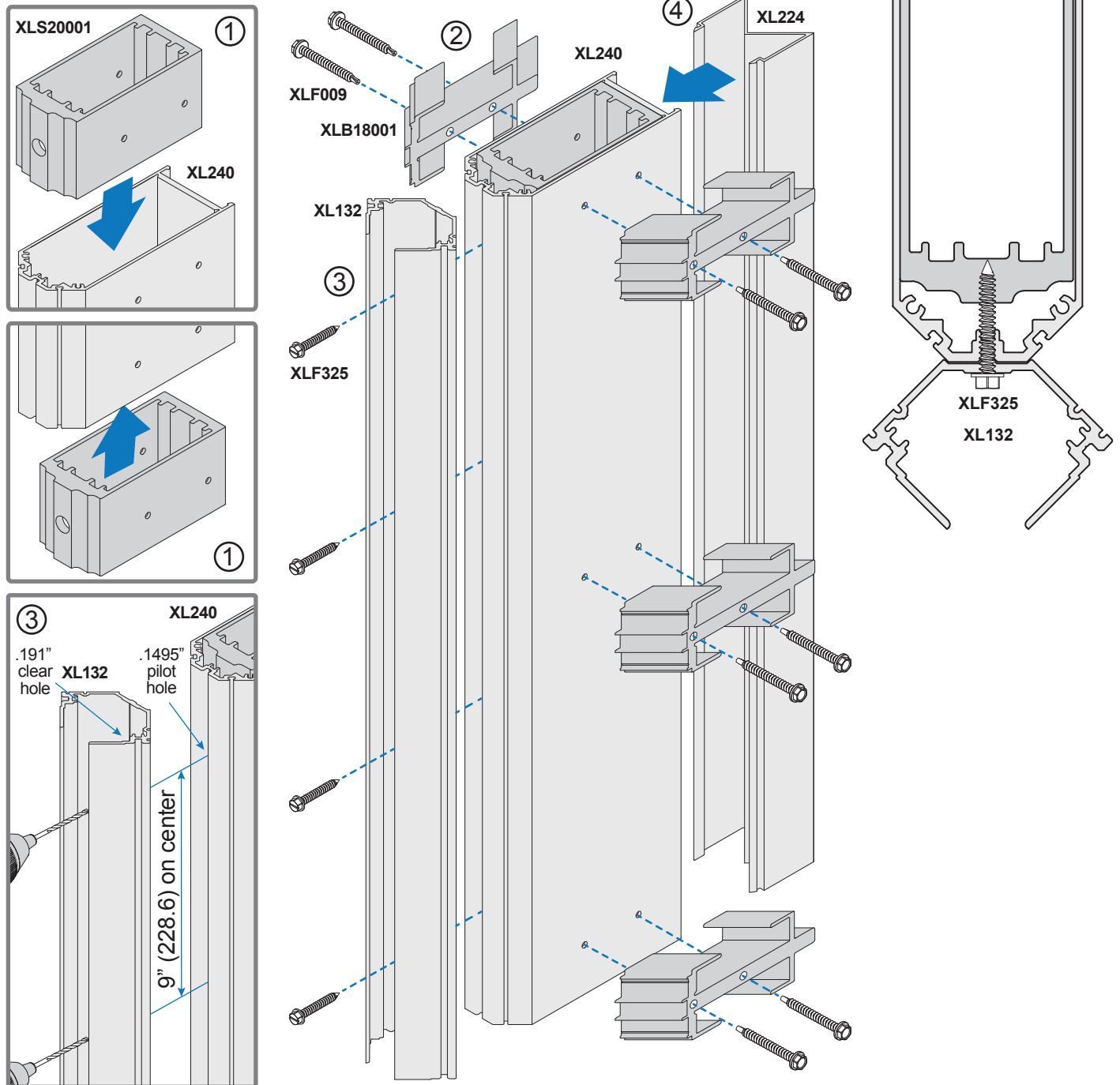



## FRAME FABRICATION (CONTINUED)

### Mullion Fabrication for Stacked Horizontal

Fabricate top of Top Mullion and bottom of Bottom Mullion as shown on previous pages.

- ① Install XLB18002, XLB18003 or XLB18401 Shear Block with XLF009 screws at bottom of Top Mullion.
- ② Install XLB18002, XLB18003 or XLB18401 Shear Block with XLF009 screws at top of Bottom Mullion.

NOTE: Do Not install Anchor Sleeve where XLB18002, XLB18003 or XLB18401 Shear Block are installed.

#### Top Intermediate Mullion

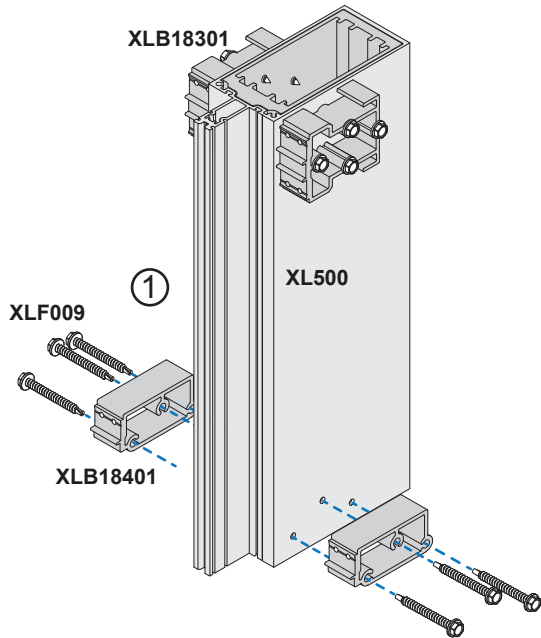

#### Top Corner Mullion

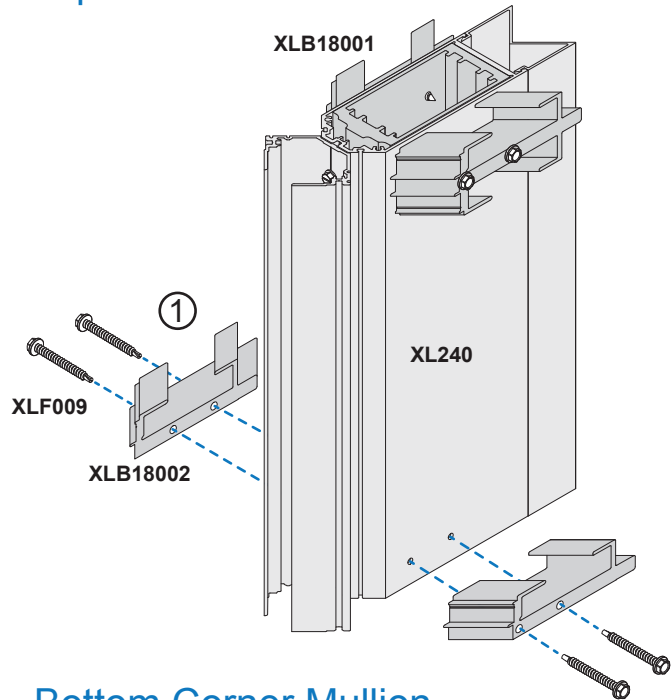

#### Bottom Intermediate Mullion

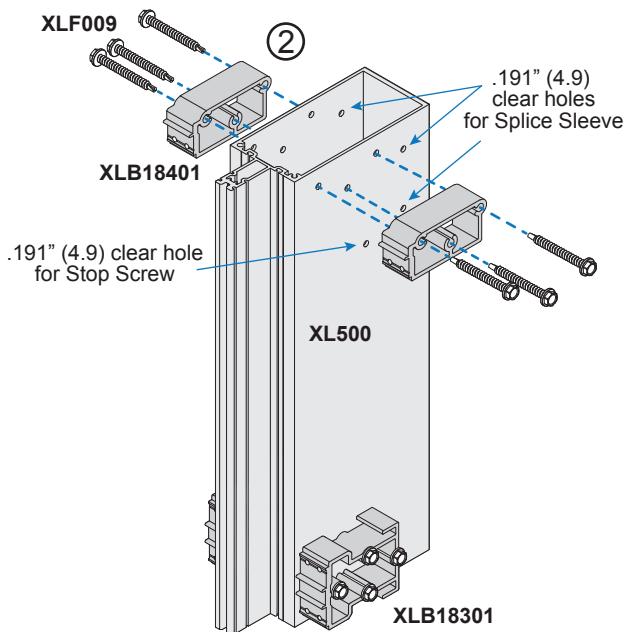

#### Bottom Corner Mullion

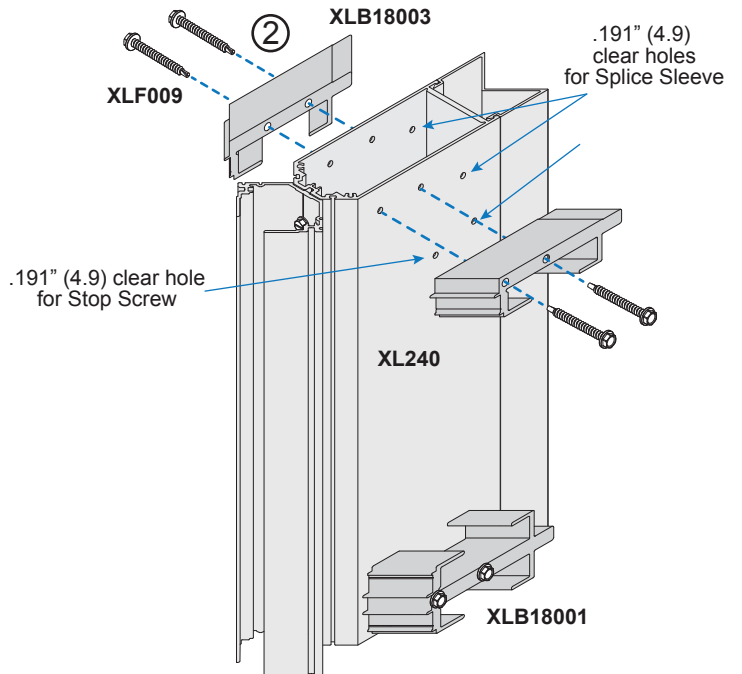

Intermediate Mullion shown. Jamb and SSG Mullion similar.

# FRAME FABRICATION (CONTINUED)

## Horizontal Member Fabrication

Drill and counter sink (2) .191" (4.9) diameter holes 3/4" (19.1) from each end at V-Grooves for XLF118 Fasteners to secure XLB18003 Shear Blocks.

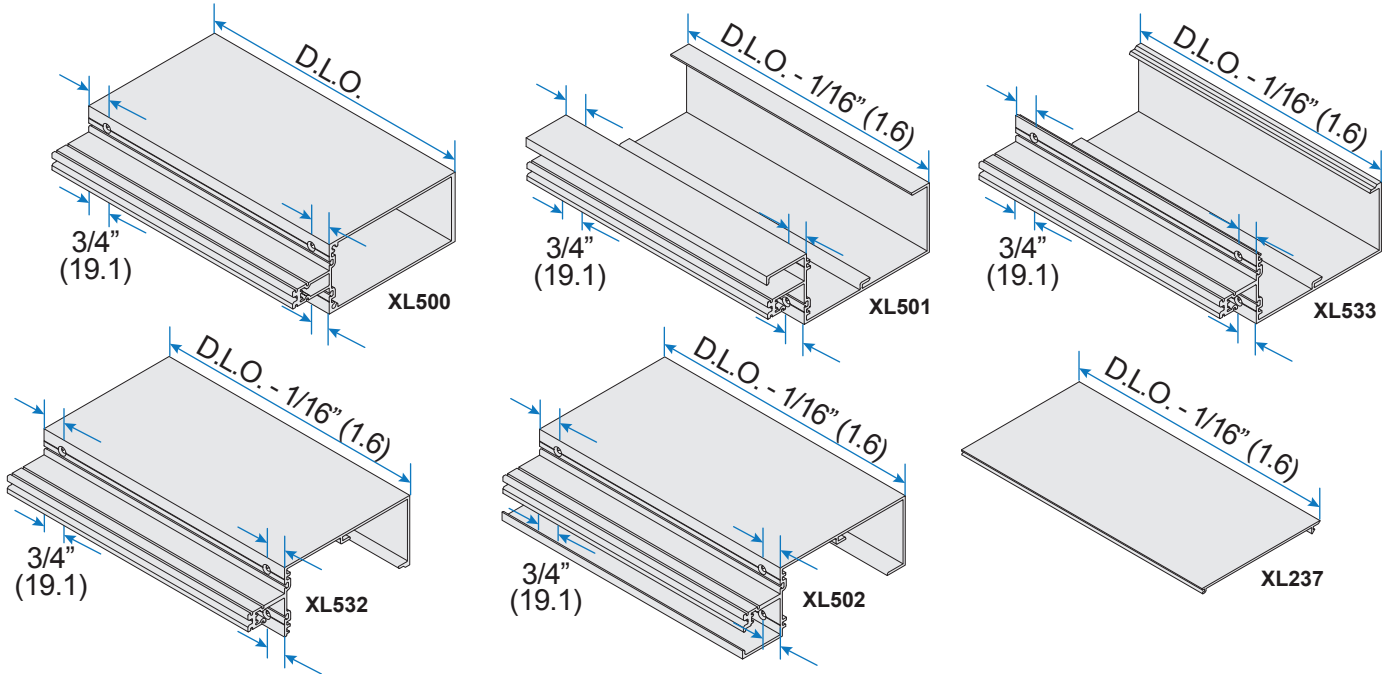

## Stacked Horizontal Fabrication

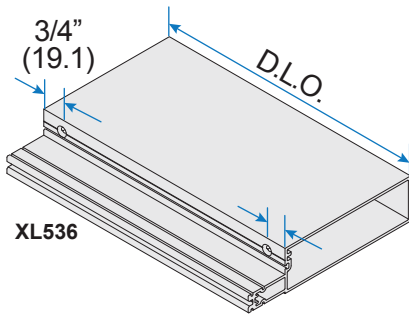

Drill and counter sink (1) .191" (4.9) diameter holes 3/4" (19.1) from each end at V-Grooves for XLF118 Fasteners to secure XLB18401 Shear Blocks.

## Corner Horizontal Fabrication

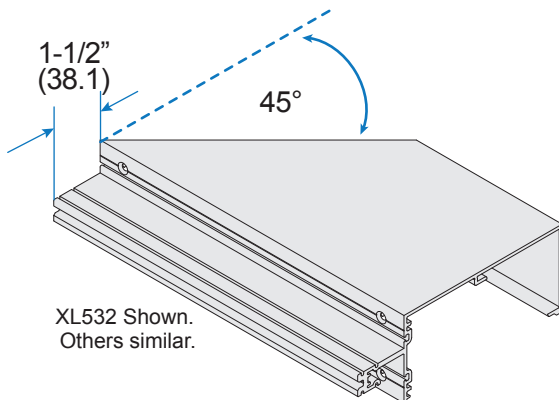

Fabricate as shown above and then miter cut end at 1-1/2" (38.1) for corner.

XL532 Shown.  
Others similar.

# FRAME FABRICATION (CONTINUED)

## Gasket Fabrication for Dry Glaze

### Dry Glaze

Cut XLG107 Isolator Gasket: Vertical to D.L.O. plus 1-1/2" (38.1) and Horizontal to D.L.O. plus 3/16" (4.8).

Cut XLG1015 Dry Glazed Gasket: Vertical to D.L.O. plus 1-1/2" (38.1) and Horizontal to D.L.O. plus 3/16" (4.8).

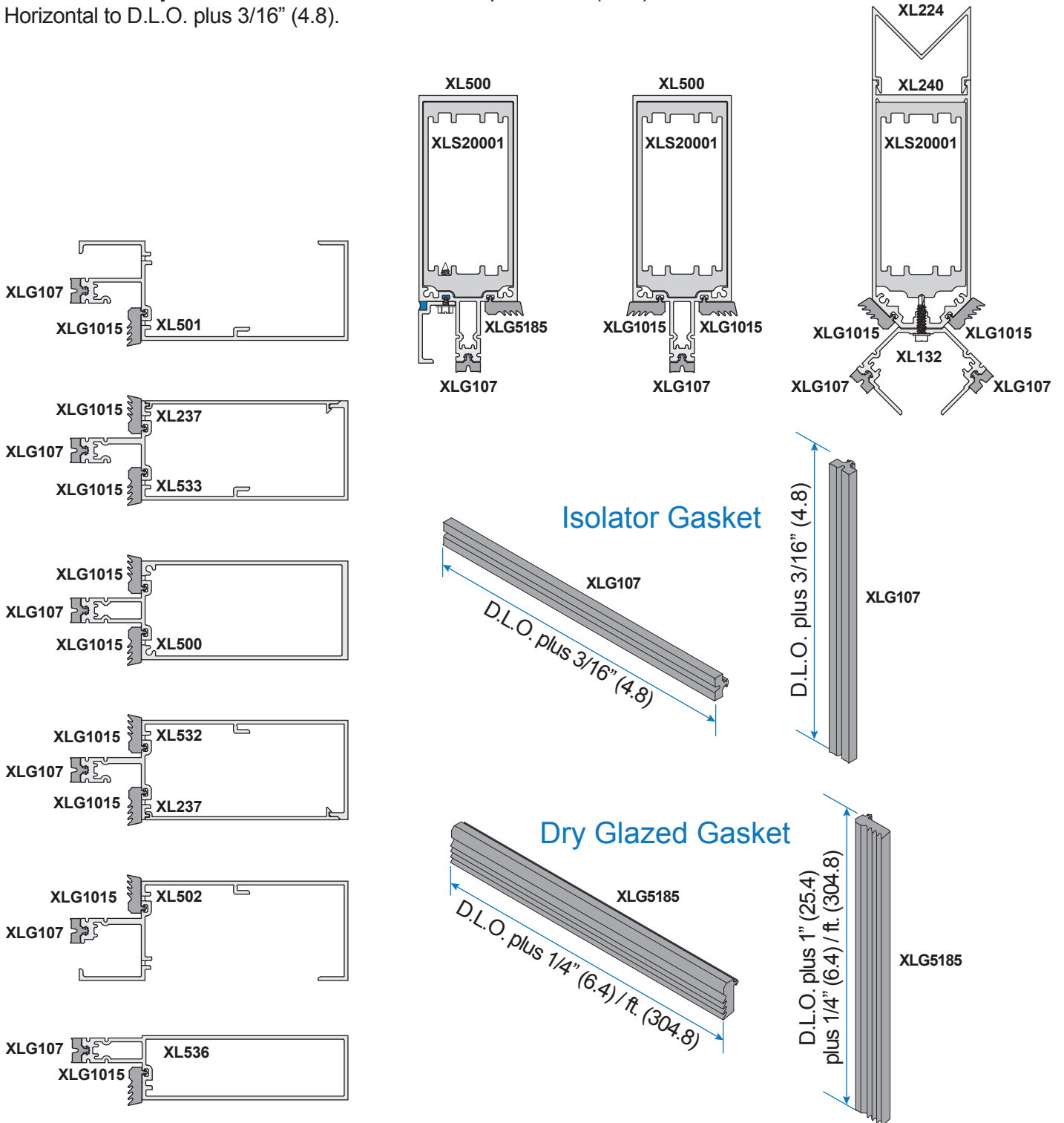

# FRAME FABRICATION (CONTINUED)

## Gasket Fabrication for Wet Glaze and SSG

### Wet Glaze and SSG

Cut XLG107 Isolator Gasket: Vertical to D.L.O. plus 1-1/2" (38.1) and Horizontal to D.L.O. plus 3/16" (4.8).  
 NOTE: SSG Vertical Mullion does not use Isolator Gasket.

Cut XLG5185 Spacer Gasket: Vertical to D.L.O. plus 1" (25.4) plus 1/4" (6.4) longer per foot (304.8) and Horizontal to D.L.O. plus 1/4" (6.4) longer per foot (304.8).

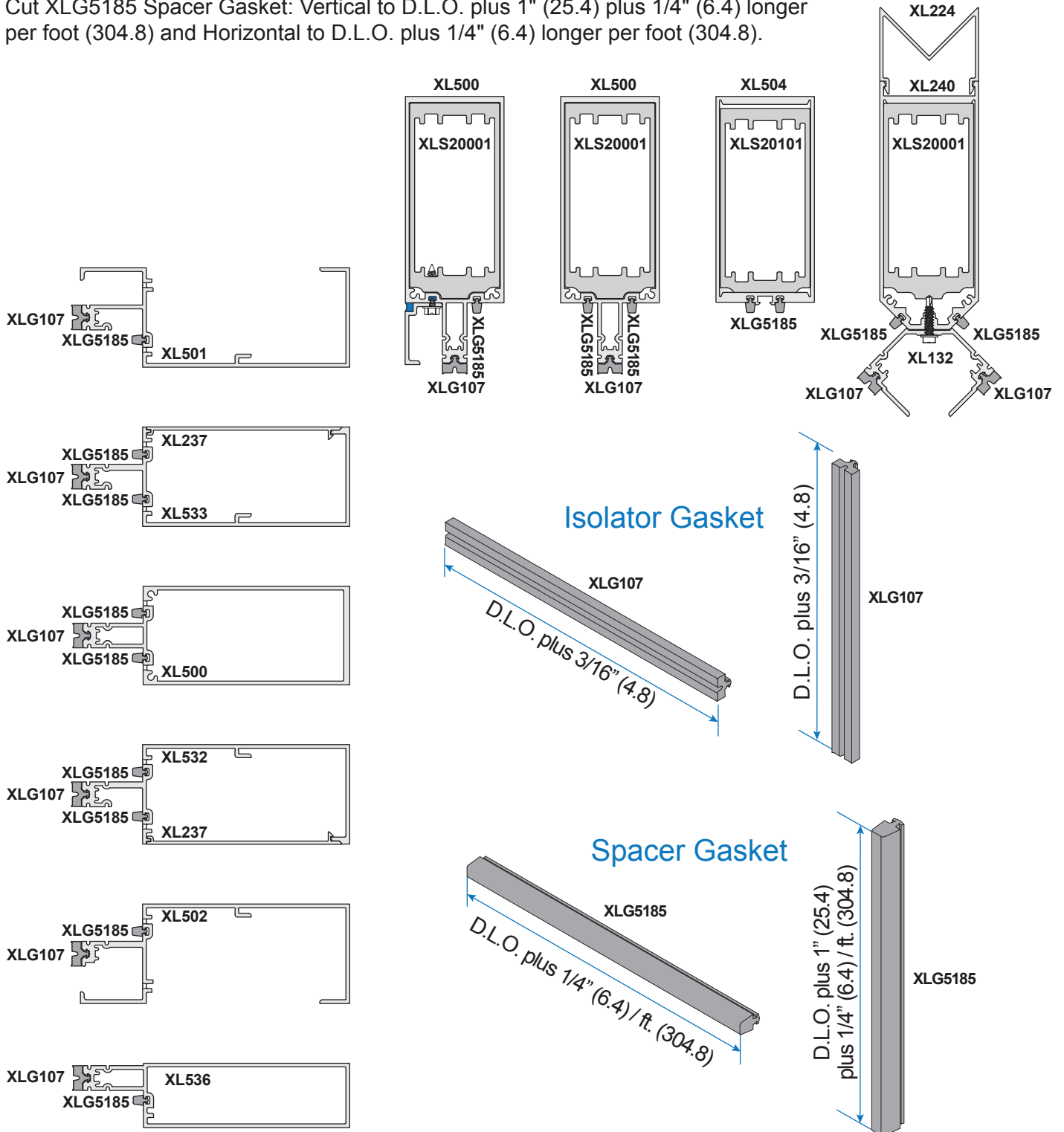

# FRAME FABRICATION (CONTINUED)

## Horizontal Pressure Plates

NOTE: XL162 and XL102 Pressure Plates are fabricated with holes every 9" (228.6). Add hole 1-1/2" (38.1) from ends if needed. Weep Holes at top when installed.

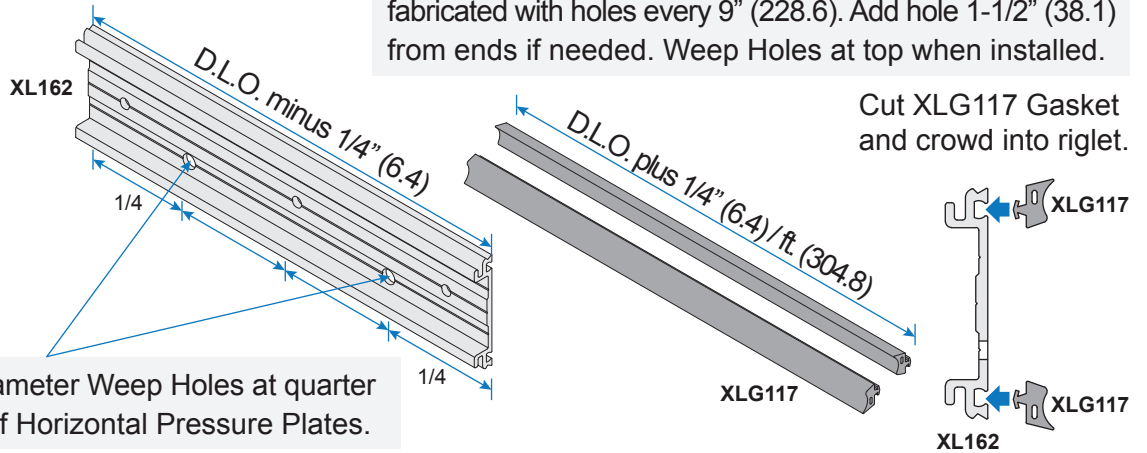

Drill (2) 5/16" (7.9) diameter Weep Holes at quarter points on V-Groove of Horizontal Pressure Plates.

NOTE: For SSG Installations, run Horizontal Pressure Plate continuous to Vertical Jambs not to exceed three lites. Vertical Pressure Plates are not used on SSG Intermediate Mullions.

## Vertical Pressure Plates

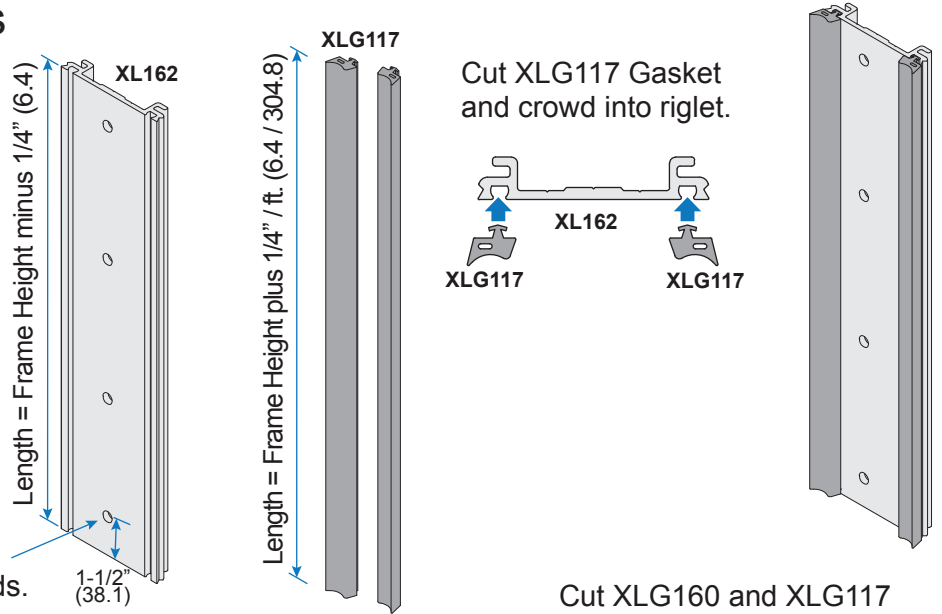

NOTE: Drill .191" (4.9) hole if needed 1-1/2" (38.1) from ends.

## Stacked Horizontal Pressure Plates

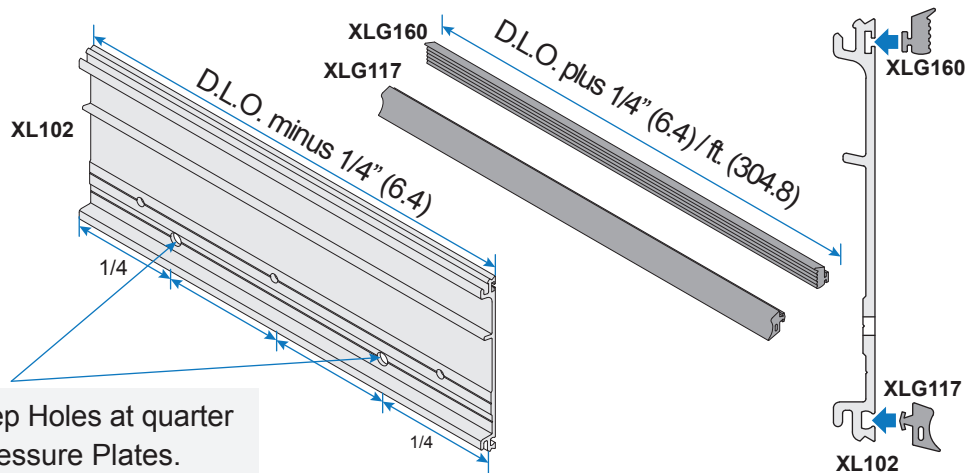

Drill (2) 5/16" (7.9) diameter Weep Holes at quarter points on V-Groove of XL102 Pressure Plates.

# FRAME FABRICATION (CONTINUED)

## Face Cap Fabrication

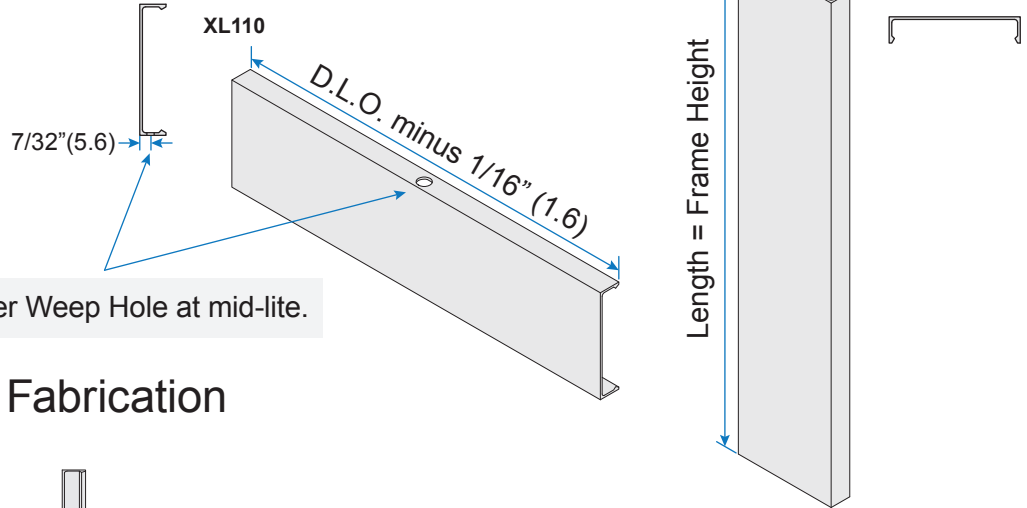

Drill  $5/16" (7.9)$  diameter Weep Hole at mid-lite.

## Corner Face Cap Fabrication

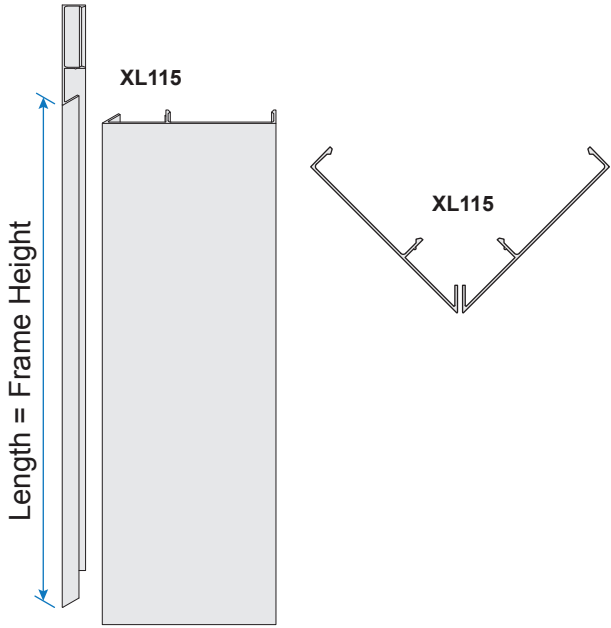

## Stacked Horizontal Face Cap Fabrication

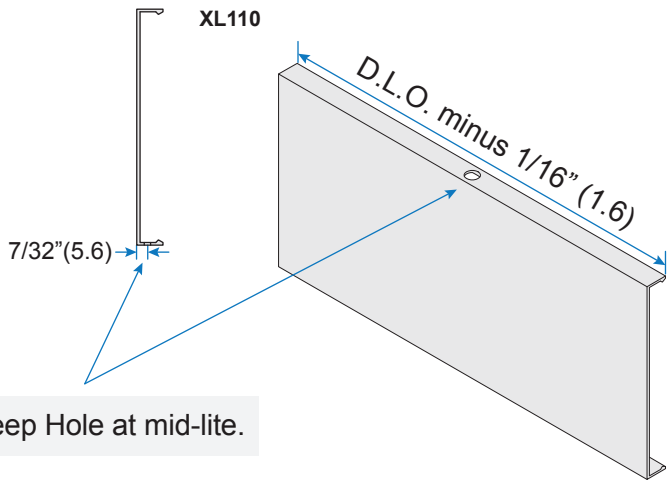

Drill  $5/16" (7.9)$  diameter Weep Hole at mid-lite.

# FRAME FABRICATION (CONTINUED)

## 9/16" Optional Glazing Adaptor Fabrication

### Wet Glaze and SSG

### Dry Glaze

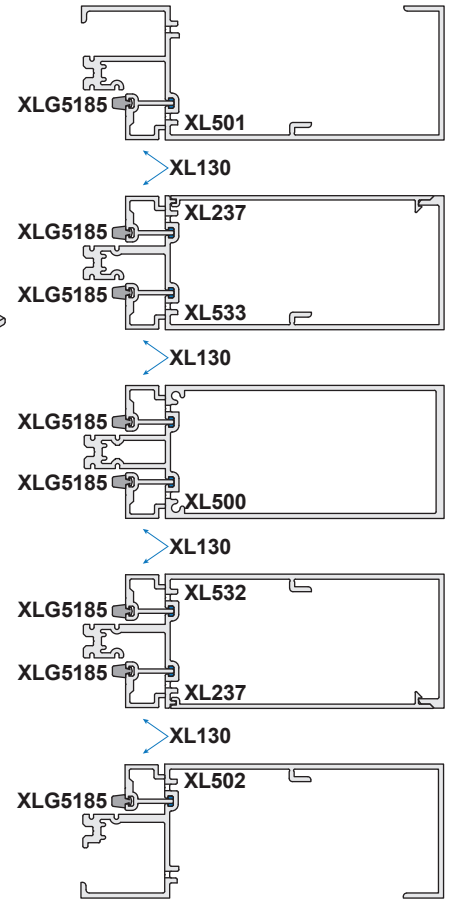
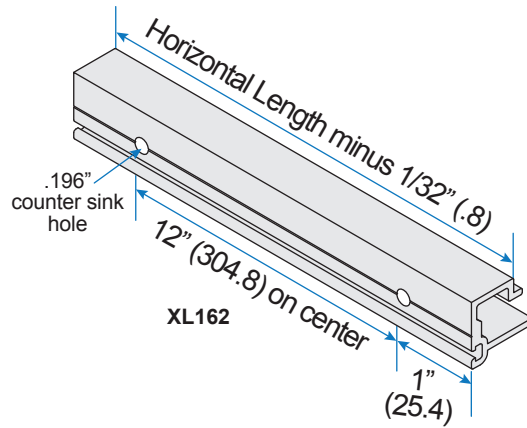
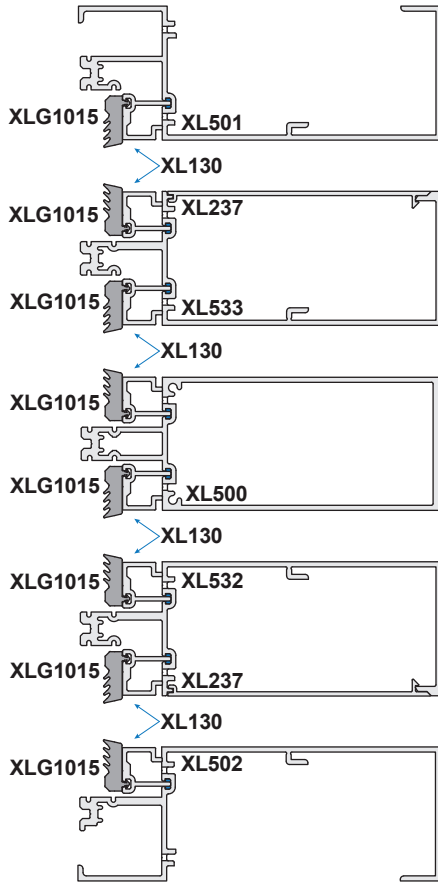

### Dry Glaze

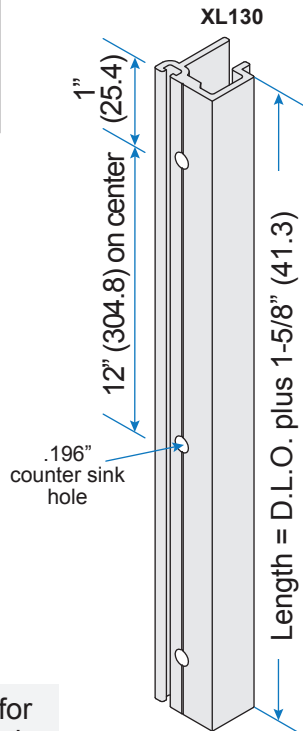
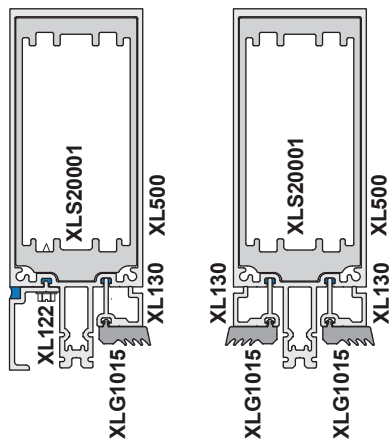

### Wet Glaze

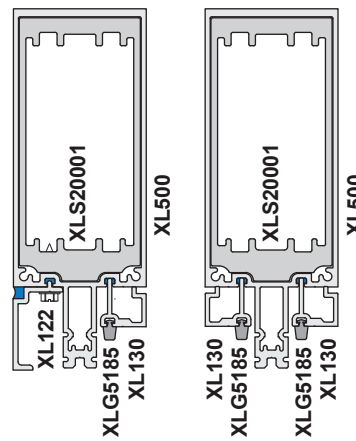

### SSG

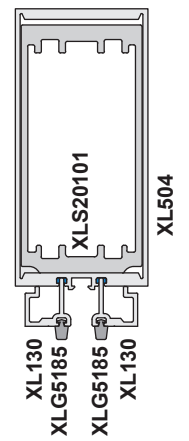

NOTE: Anchor Sleeve required for design pressures above 70 psf. only.

NOTE: Anchor Sleeve required for design pressures above 70 psf. only.

# JAMB AND MULLION INSTALLATION

- ① Apply bed of sealant to top and bottom Mullion.
- ② Attach Mullion Caps with XLF320 screws.  
NOTE: Use Mullion Cap designed for each Mullion.
- ③ Refer to Shop Drawings for location and appropriate anchor and fastener for Jamb and Vertical Mullions.

Refer to Shop Drawings for appropriate anchor.

## SSG Mullion

① XL504  
Cat. No. 795 Sealant

② XLC358 XLF320

XLC358 XLF320

- ④ Field drill anchors insert in top and bottom of mullion and temporarily attach to structure. Ensure mullions are plumb and true.
- ⑤ Shim and anchor into opening.

## Jamb

① XL500  
Cat. No. 795 Sealant

② XLC338 XLF320

XLC338 XLF320

## Corner Mullion

① XL240  
Cat. No. 795 Sealant

② XLC323 XLF320

XLC323 XLF320

## Intermediate Mullion

① XL500  
Cat. No. 795 Sealant

② XLC325 XLF320

XLC325 XLF320

④

④

NOTE: Jamb shown.



# HORIZONTAL MEMBER INSTALLATION

- ① Apply sealant to shear blocks as shown.  
NOTE: Adequate sealant should be applied in track to allow sealant to force through holes in horizontal.
- ② Slide Horizontal Member into opening from back to front and against Shear Block. Ensure it hooks onto Shear Block and slide into place. Sealant is forced through attachment holes.
- ③ Attach Horizontal with two XLF118 screws at each end.

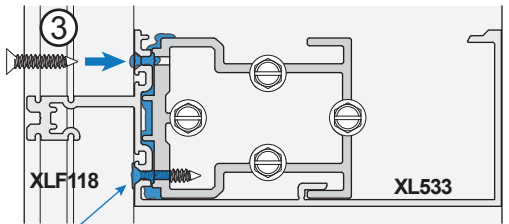
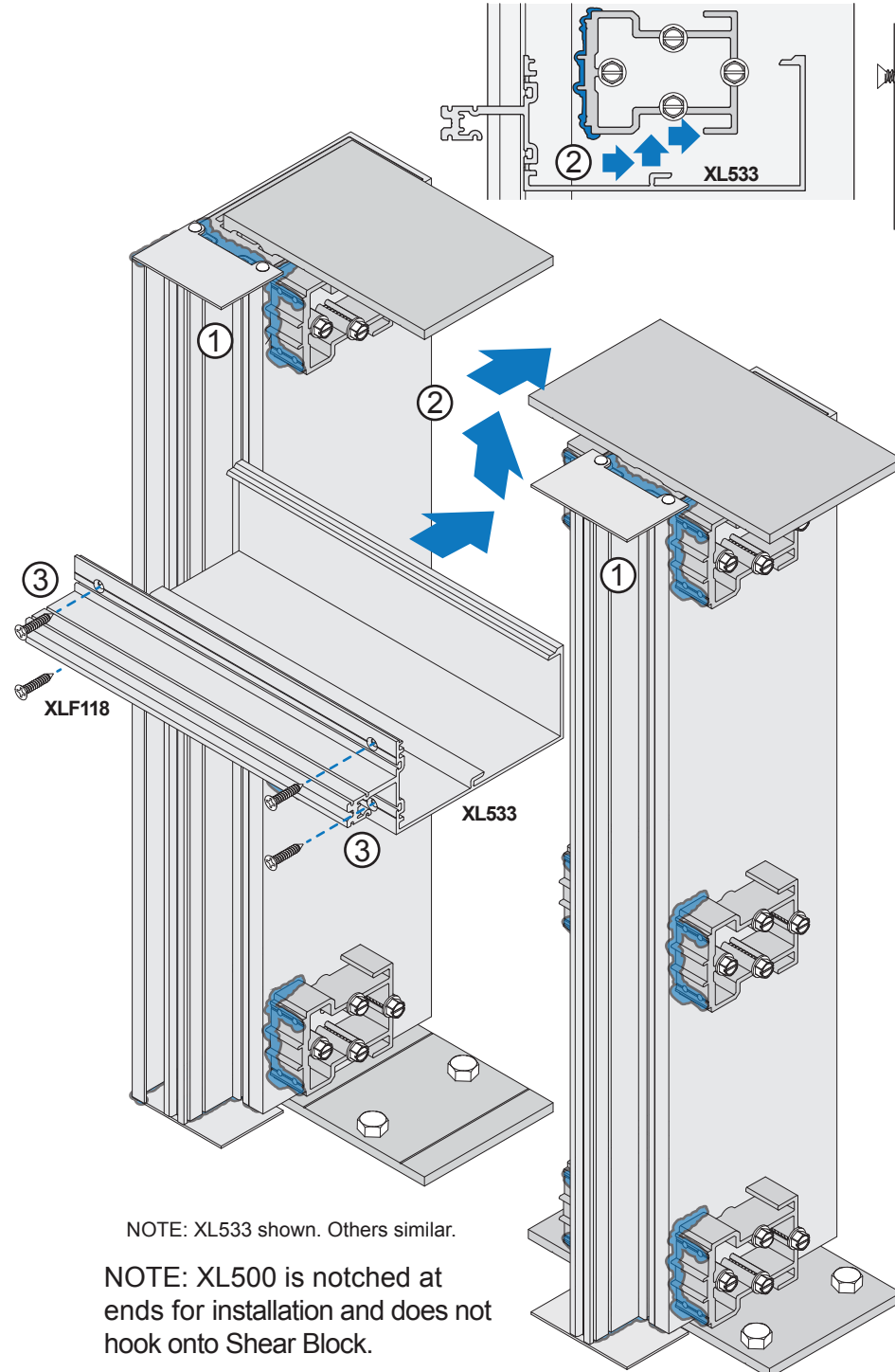
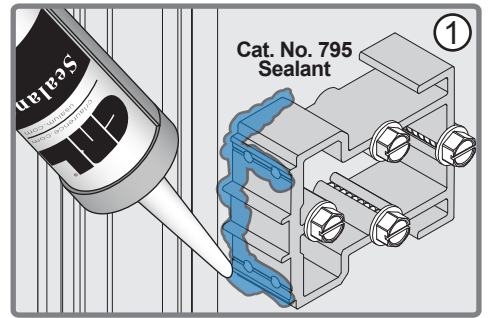

**IMPORTANT:** If sealant does not form a complete seal around screw head, apply cap seal to ensure proper seal.

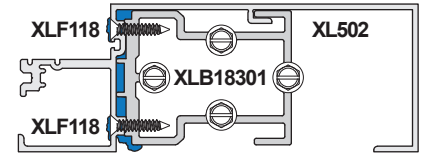
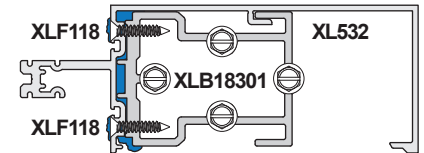
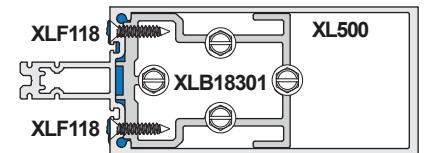
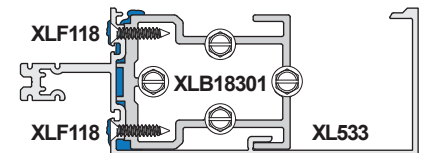
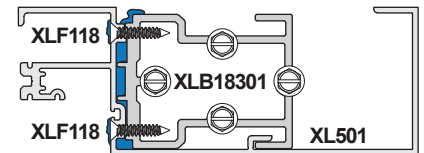
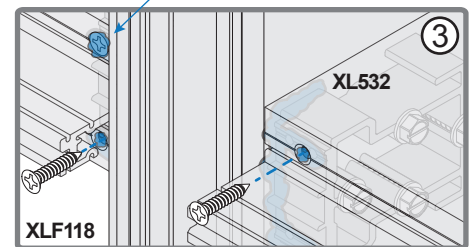

NOTE: XL533 shown. Others similar.

NOTE: XL500 is notched at ends for installation and does not hook onto Shear Block.

# 9/16" GLAZING ADAPTOR INSTALLATION

- ① Dry fit Vertical Glazing Adaptors in Vertical Mullions. Match drill holes and remove Adaptor.
- ② Bed reglet with with Cat. No. 795 Silicone Sealant.
- ③ Attach Adaptor with XLF119 screws.
- ④ Cap seal over screw head with Cat. No. 795 Silicone Sealant.
- ⑤ Repeat Steps 1 - 4 to install Horizontal Adaptors.

NOTE: See Page 23 for Adaptor location and fabrication. Intermediate Vertical Mullion shown below. Install Vertical Adaptors, then Horizontal Adaptors.

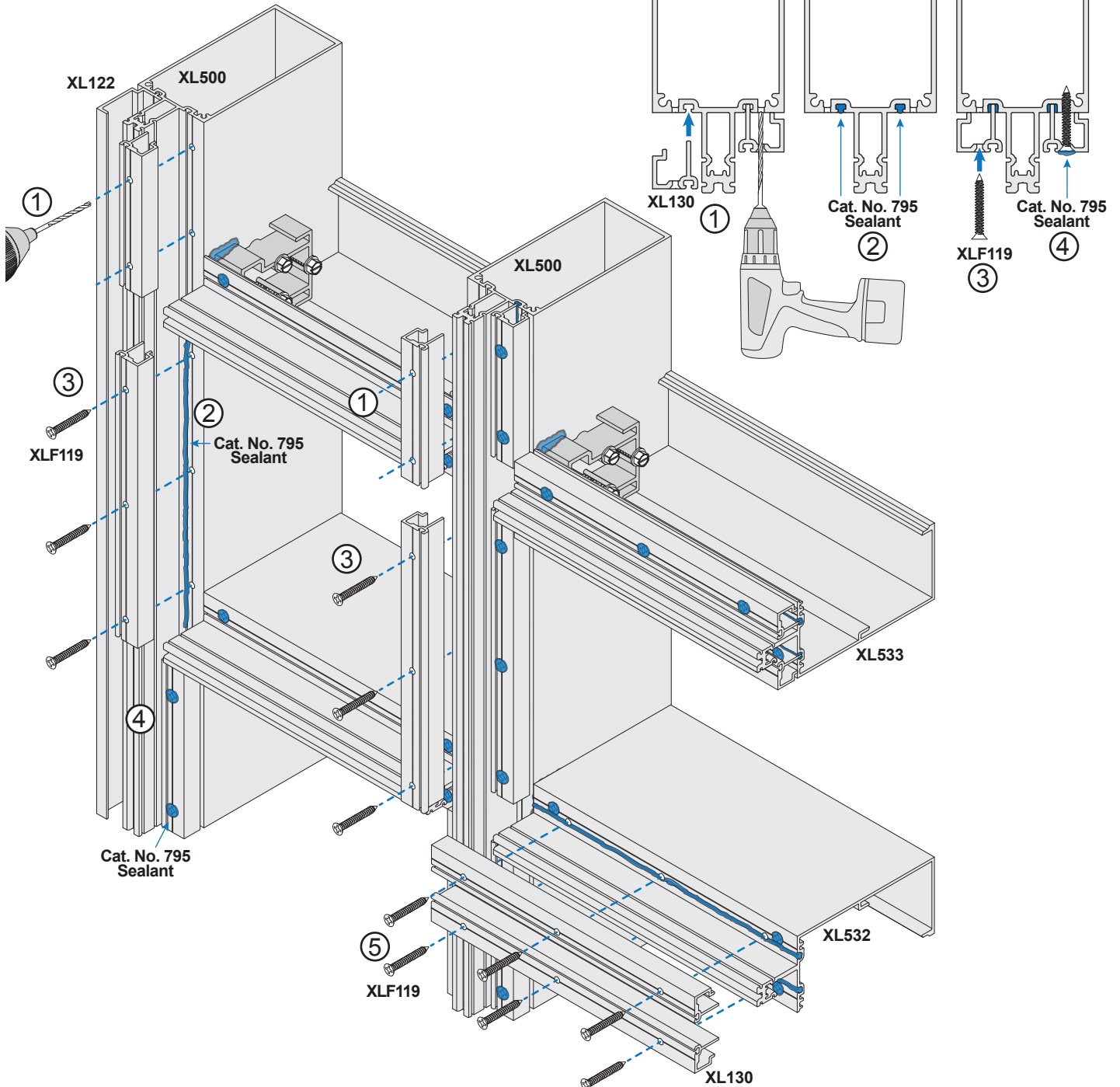

## HORIZONTAL FILLER INSTALLATION

- ① Insert Filler front leg into receptor leg of XL532 or XL533.
- ② Rotate Filler until it engages in rear snap.
- ③ Tap with Rubber Mallet to fully engage.

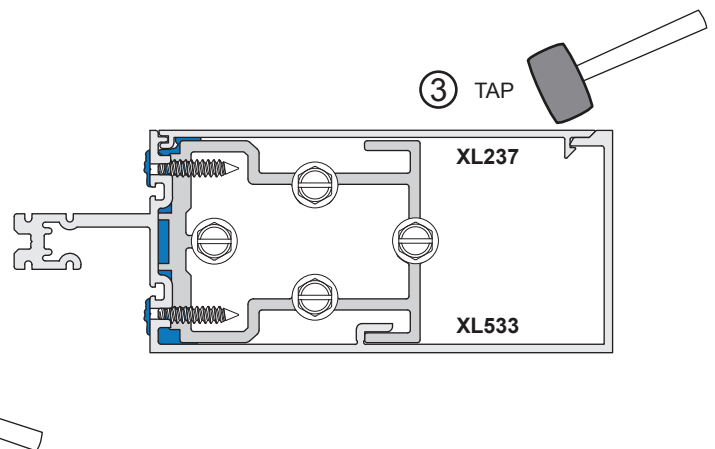
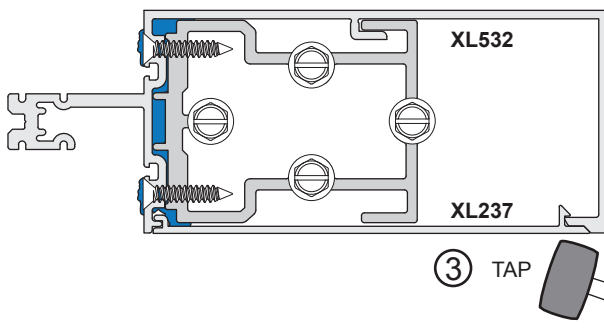
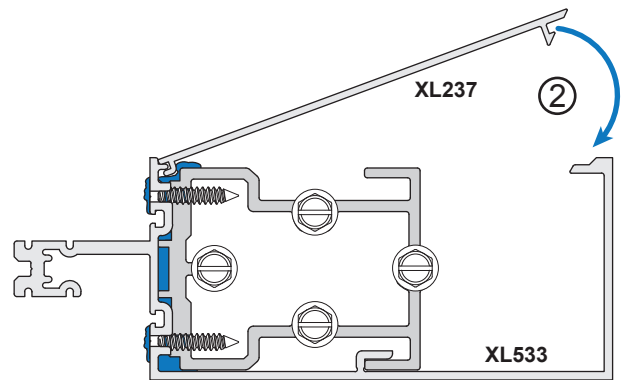
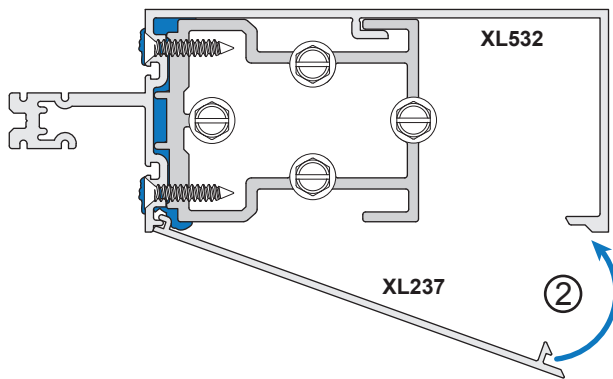
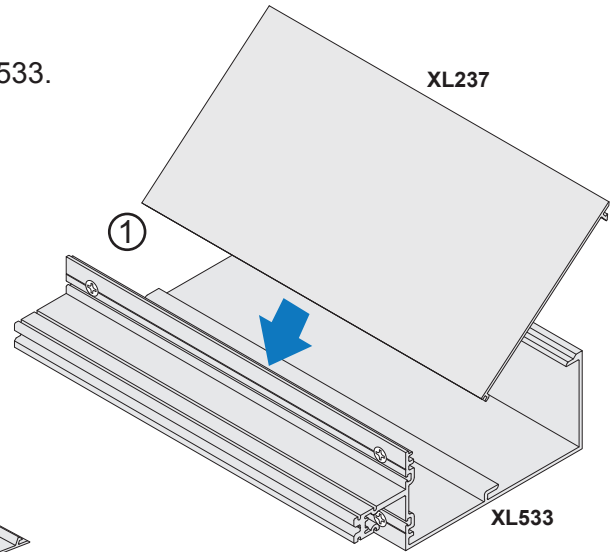
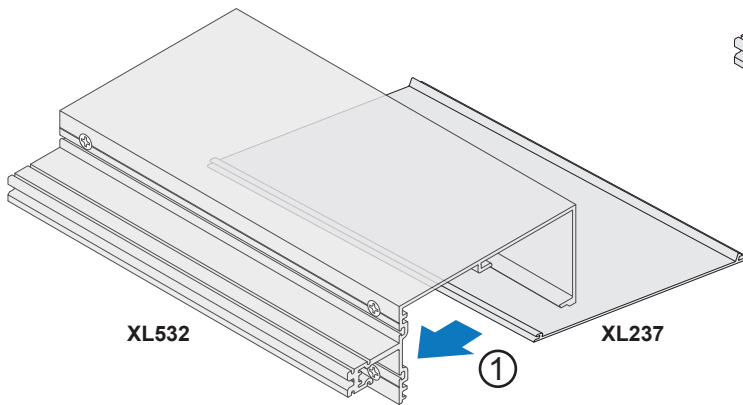

## PERIMETER SEALING

- ① Position Backer Rod around the perimeter of the frame.
- ② Clean gap area on frames with 50% Isopropyl Alcohol.
- ③ Apply and tool Cat. No. 795 Silicone Sealant to the perimeter of the frame.

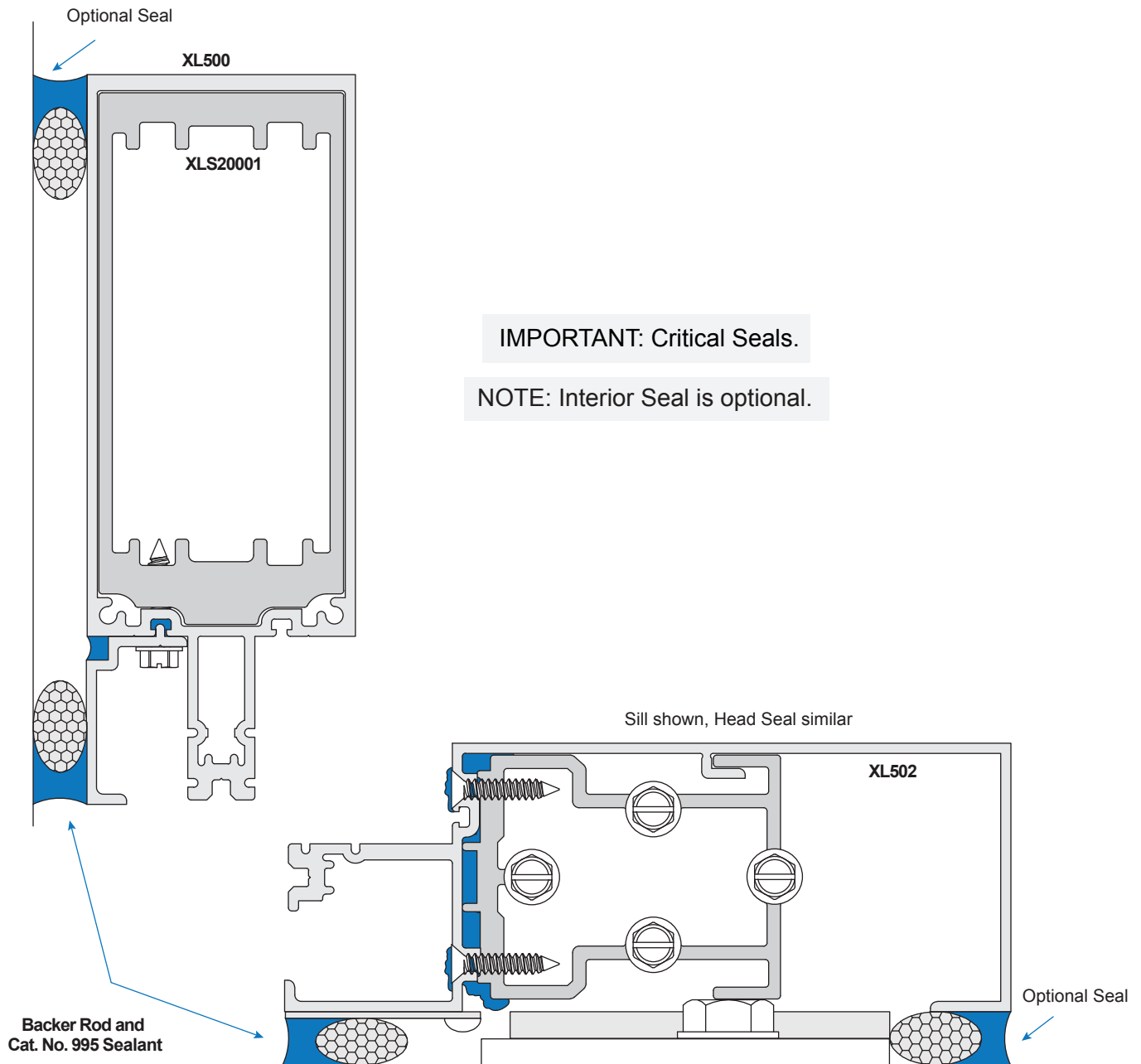

## END DAM INSTALLATION

- ① Apply bed of Cat. No. 795 Silicone Sealant along tongue of Horizontal and across face and tongue of Vertical Mullion.
- ② Insert XLD352 End Dam into sealant.
- ③ Seal and tool along top and bottom of End Dam to form water tight seal.  
NOTE: Critical Seal. Force sealant into Gasket Race.
- ④ Seal Head at Mullion Cap.
- ⑤ Seal Sill at Mullion Cap.

IMPORTANT: Critical Seals.

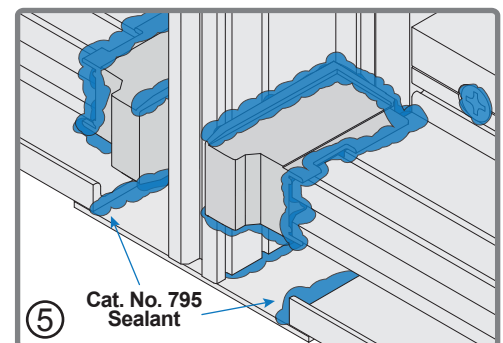
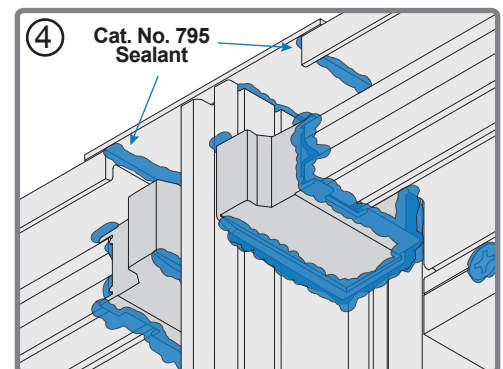
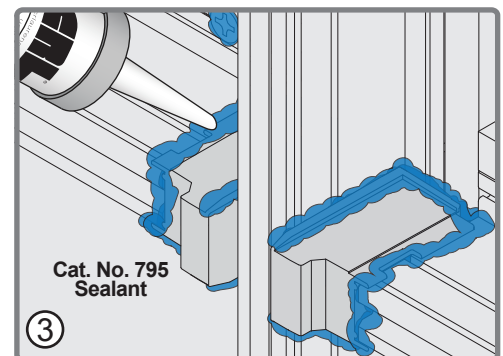
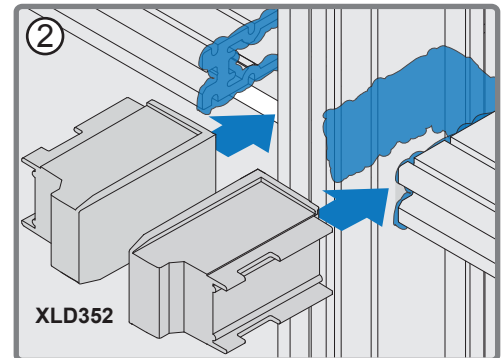
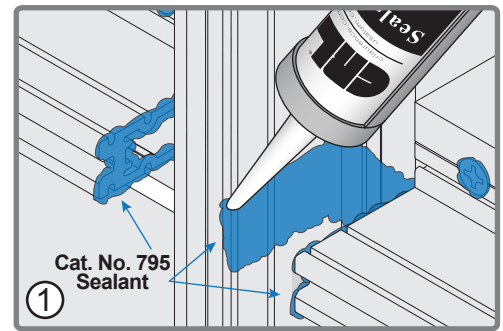
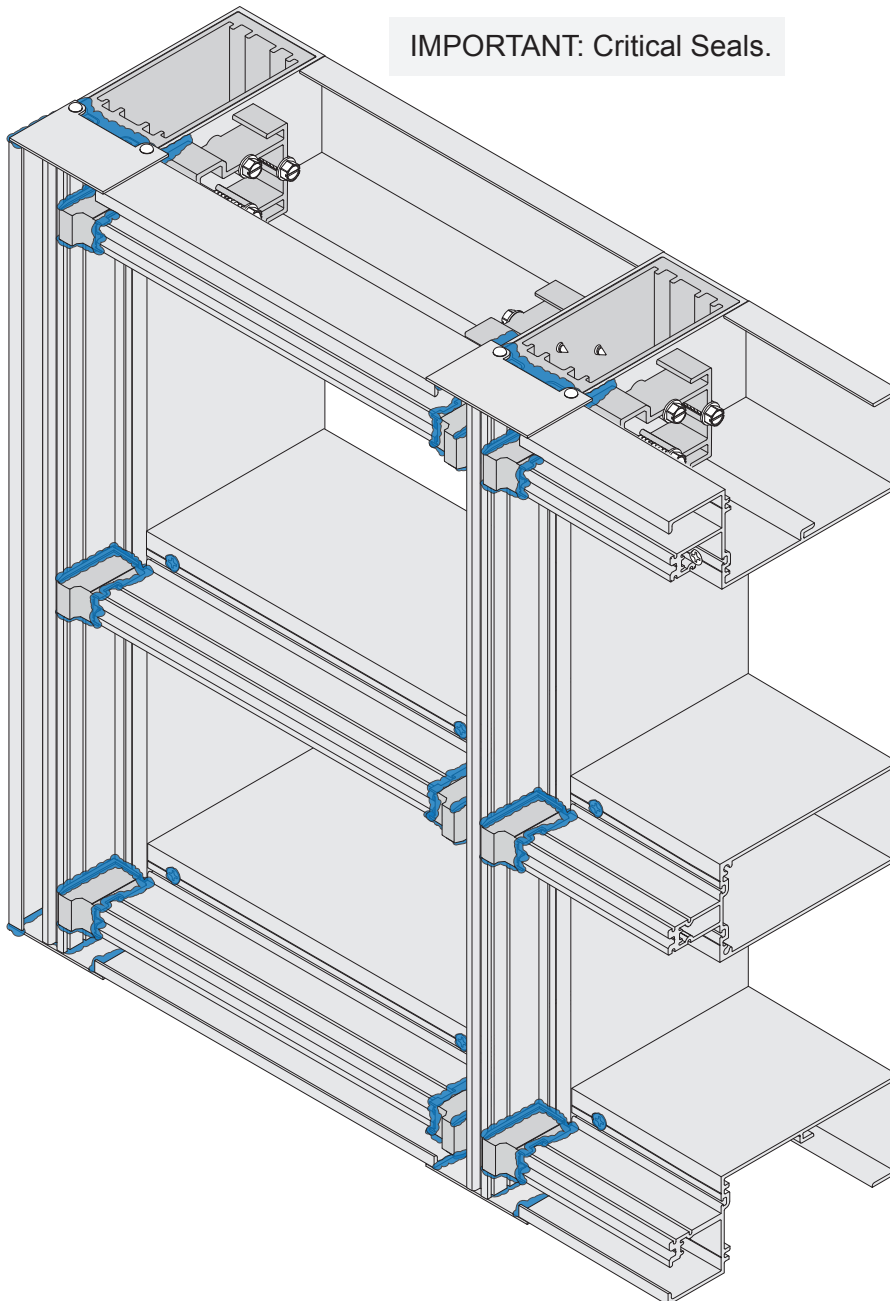

## WATER DEFLECTOR FOR SSG INSTALLATION

- ① Apply bed of Cat. No. 795 Silicone Sealant along tongue of Horizontal and across face and tongue of Vertical Mullion.
- ② Insert XLD350 Water Deflector into sealant.
- ③ Seal and tool along top and bottom of Water Deflector to form water tight seal.  
NOTE: Critical Seal. Force sealant into Gasket Race.
- ④ Seal Head at SSG Mullion Cap.
- ⑤ Seal Sill at SSG Mullion Cap.

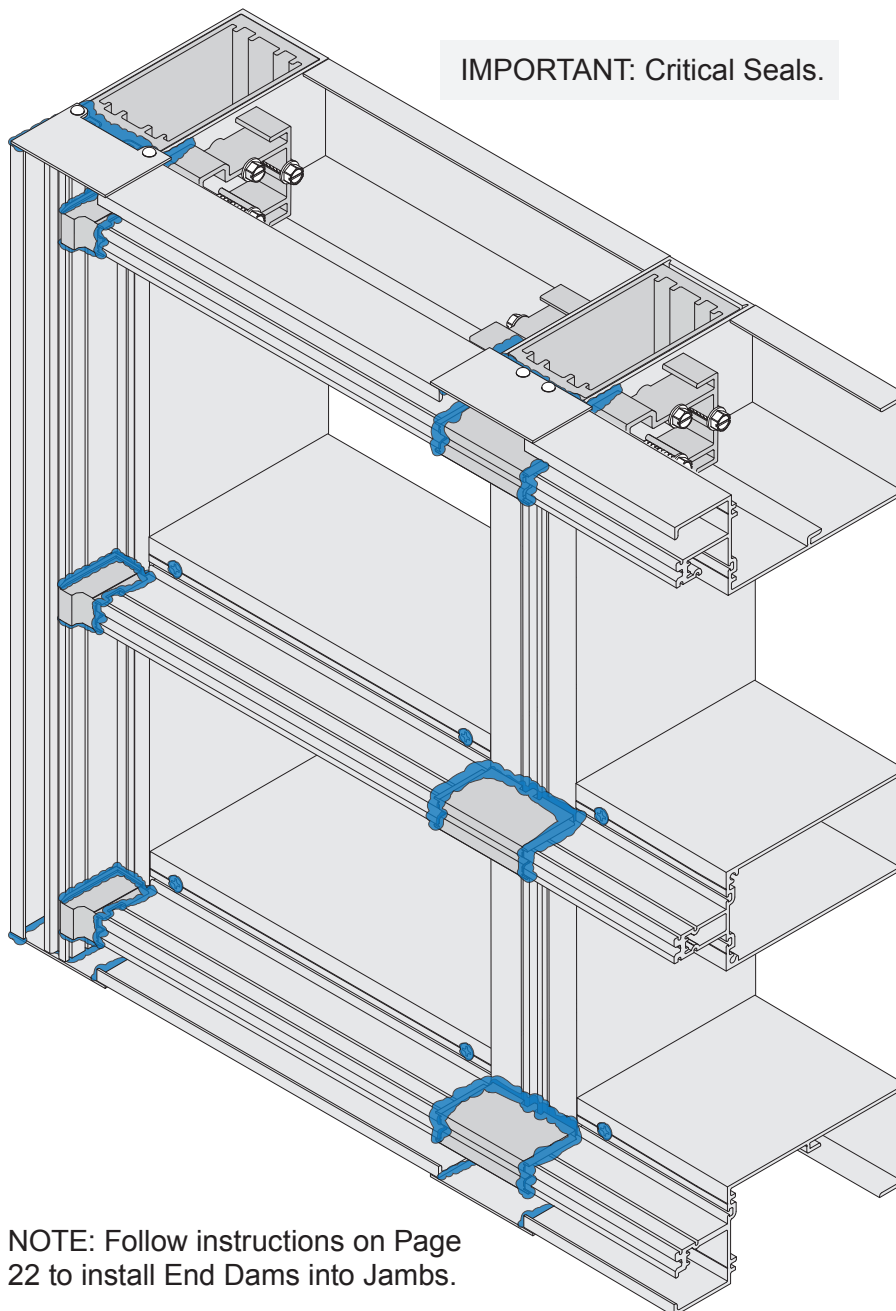
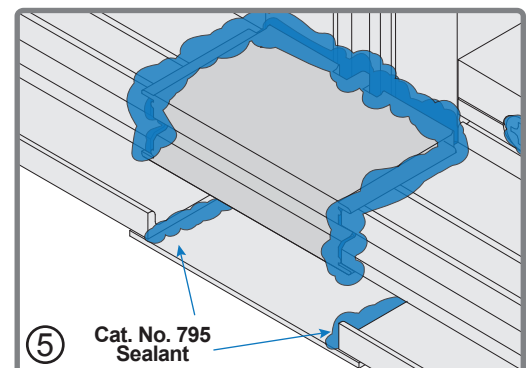
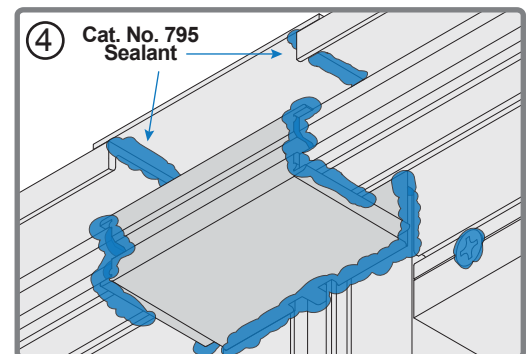
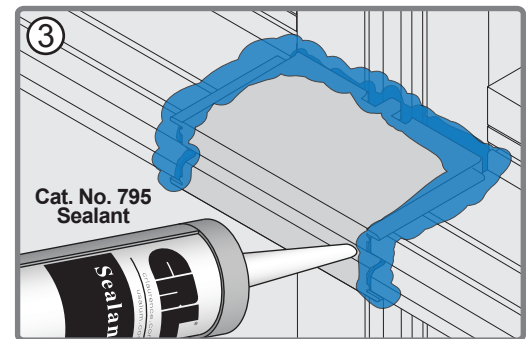
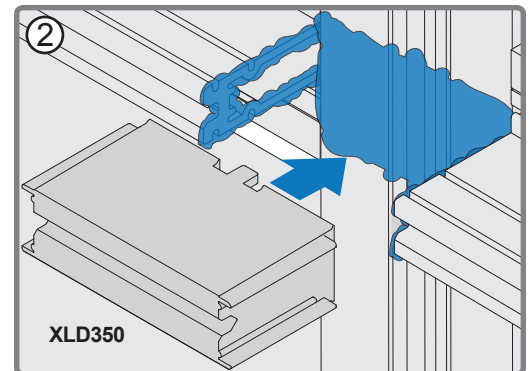
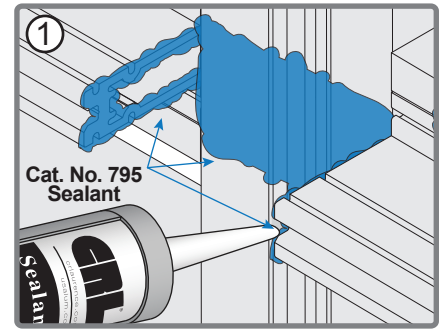

NOTE: Follow instructions on Page 22 to install End Dams into Jamb.

# GLAZING GASKET INSTALLATION

## Dry Glaze

- ① Apply Cat. No. 795 Silicone Sealant to reglets at mullion intersections 2" (50.8) in both directions.
- ② Install Vertical XLG1015 Dry Glazed Gasket with Vinyl Roller. Begin at center and work to ends.
- ③ Install Horizontal XLG1015 Dry Glazed Gasket with Vinyl Roller. Begin at center and work to ends.
- ④ Seal gasket joint.

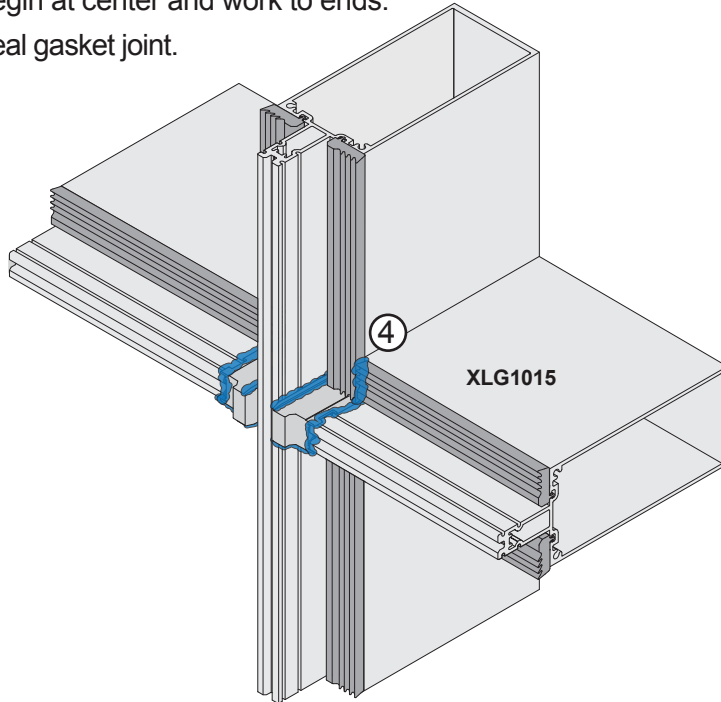

NOTE: See Page 19 for Gasket fabrication and location. See Page 23 for use with Glazing Adaptor. Install Vertical Gaskets, then Horizontal Gaskets.

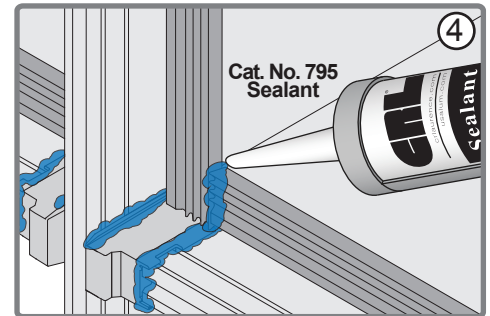
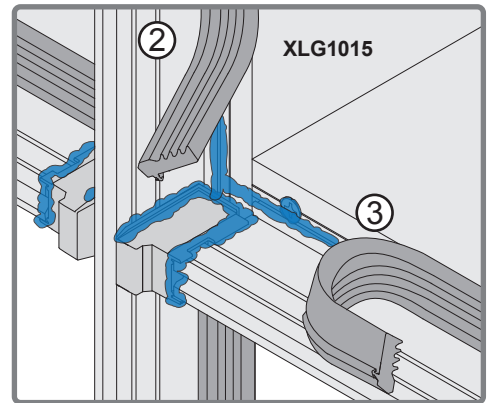
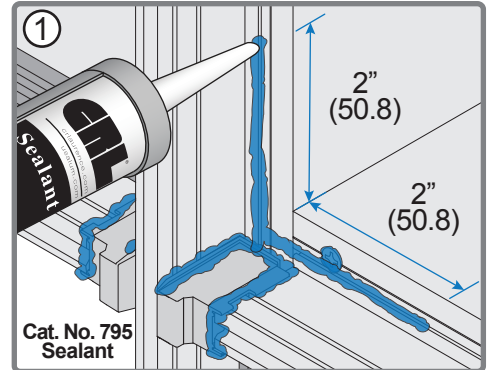

## Wet Glaze and SSG

- ① Insert Vertical XLG5185 Spacer Gasket into reglet. NOTE: Vertical Gaskets are cut short.
- ② Install Horizontal Spacer Gasket.

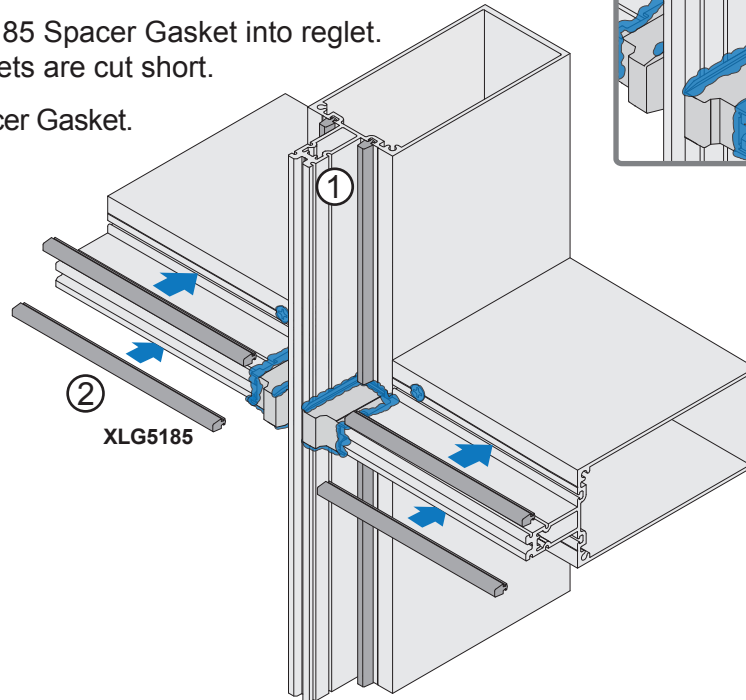

# ISOLATOR GASKET INSTALLATION

- ① Cut XLG107 Isolator Gasket 1/8" (3.2) short from mullion ends.
- ② Install Vertical XLG107 Isolator Gasket in groove on face of mullion tongue.
- ③ Install Horizontal XLG107 Isolator Gasket in groove on face of mullion tongue.

NOTE: Vertical Isolator Gasket is not used on XL504 SSG Mullion.

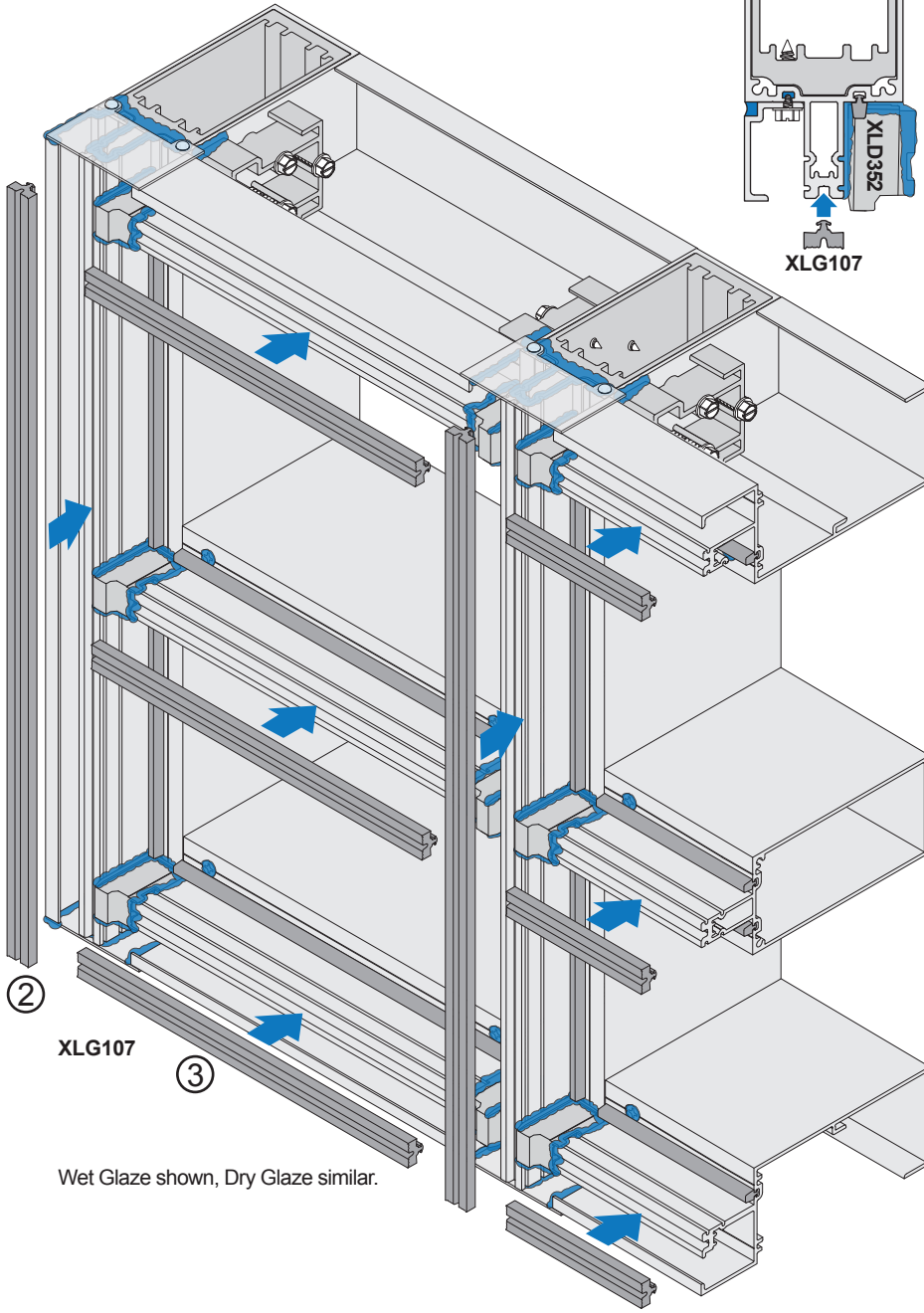

XLG107

Wet Glaze shown, Dry Glaze similar.

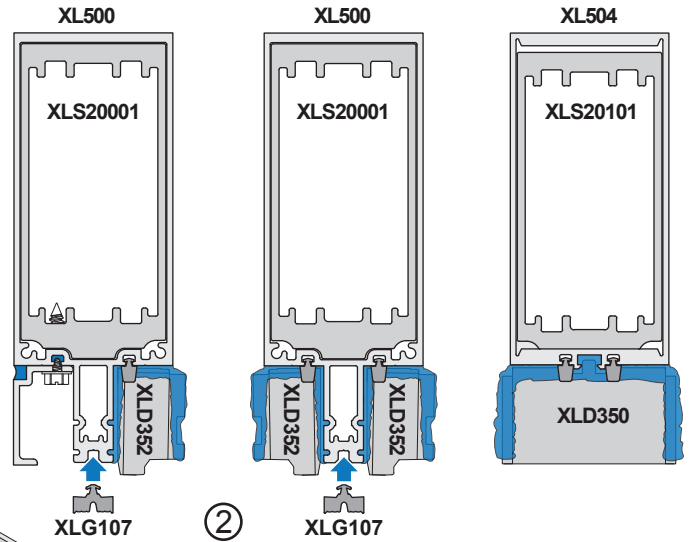

NOTE: For SSG Installation, Horizontal Isolator Gasket runs continuous over SSG Mullion.

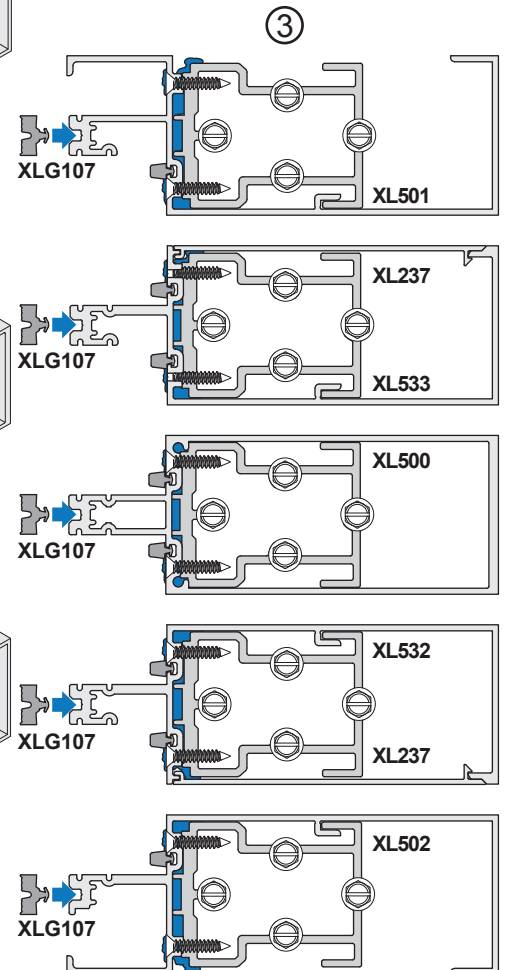



# GLASS INSTALLATION

- ① Position Setting Blocks and lubricate top of blocks to ensure proper setting of glass.

NOTE: Refer to approved Shop Drawings and consult Glass Manufacturer for correct Setting Block location for glass sizes.

- ② Set glass in opening and ensure glass bite is equal on all sides.

IMPORTANT: Ensure glass is placed firmly against interior gasket to ensure proper seal. Avoid binding of glass on Setting Block.

- ③ Temporarily hold glass in opening with XLR33301 Glazing Retainer. Torque XLF325 screw to 90 in-lbs.

NOTE: Glazing Retainers must be applied at each glass edge 3" (76.2) from the corner (minimum of 8 per lite). Glass edges greater than 48" (1219) in length but less than 96" (2438) require an additional retainer at the glass mid-span. Retainers are intended for short term use only. Additional retainers may be required to withstand full design wind load pressures. Full length pressure plates must be installed if severe weather or high wind loads are anticipated.

NOTE: Work row by row up the elevation.

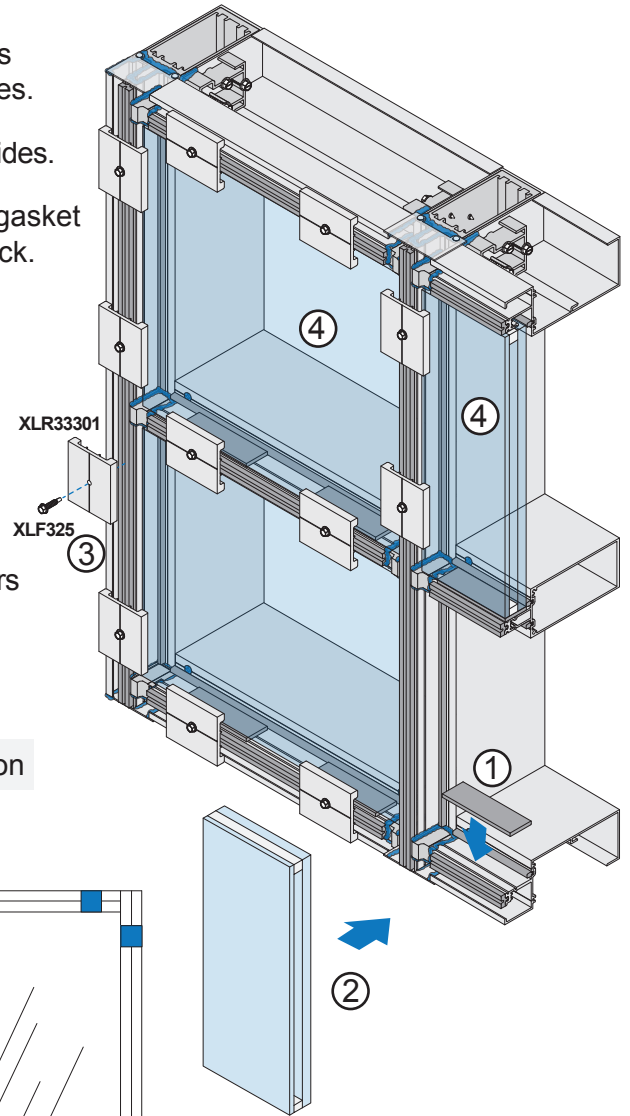

Typical Temporary Glazing Retainer Location

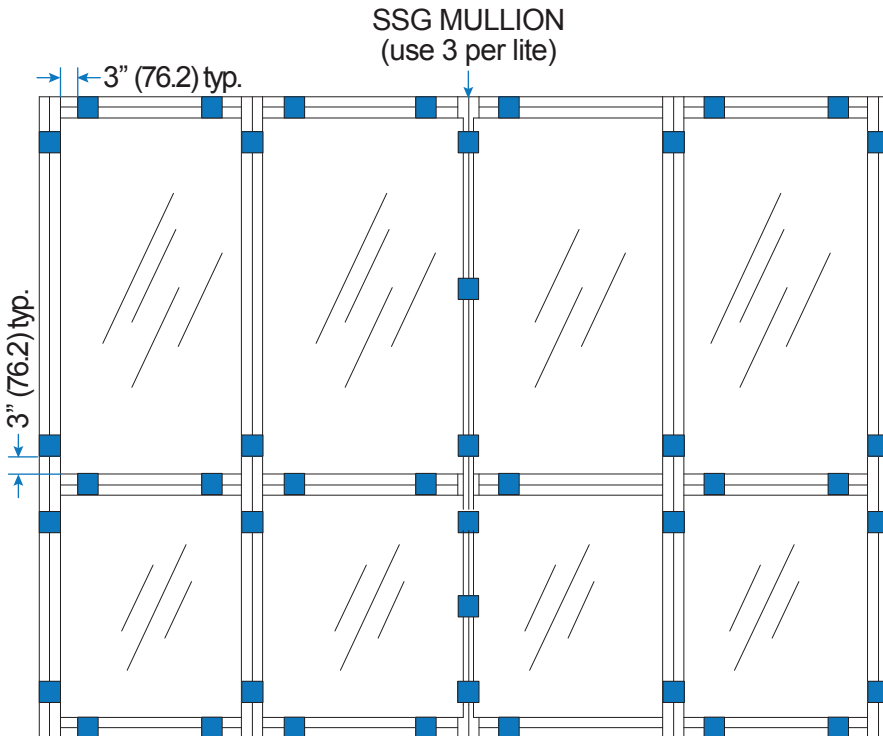

- ④ Repeat steps 1 through 3 on the next row up. Continue repeating until all glass is set.

# PRESSURE PLATE INSTALLATION

- ① Seal face of XLD352 End Dam and fill gap between End Dam and Isolator with Cat. No. 795 Silicone Sealant.

NOTE: Isolator continuous over XLD350 Water Deflector at SSG Mullion so no additional sealing required.

- ② Remove Vertical Glazing Retainers. Install Vertical Pressure Plates leaving 1/8" (3.2) gap at ends.
- ③ Remove Horizontal Glazing Retainers. Install Horizontal Pressure Plates with Weep Holes at top leaving 1/8" (3.2) gap at ends.

NOTE: Horizontal Pressure Plates continuous over SSG Mullion.

- ④ Torque all XLF325 screws to 90 in-lbs.

NOTE: The use of either a drill motor with a torque limiter or torque wrench can be used. If using a cordless drill, check torque periodically since battery usage will affect the torque setting.

NOTE: See Page 21 for Pressure Plate and Gasket fabrication. Ensure Pressure Plates are pinned 1-1/2" (38.1) from ends. Orient Weep Holes at top.

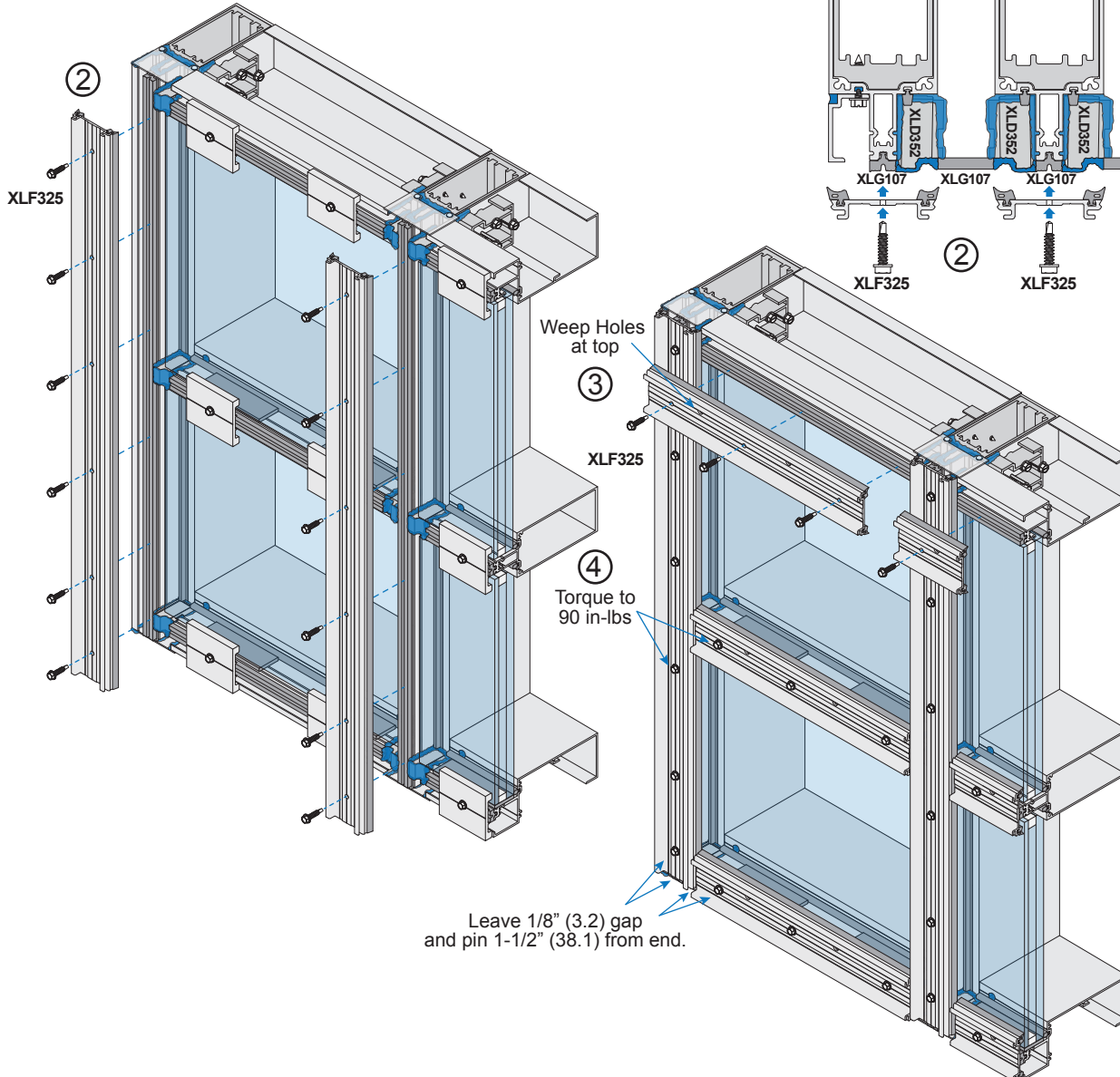
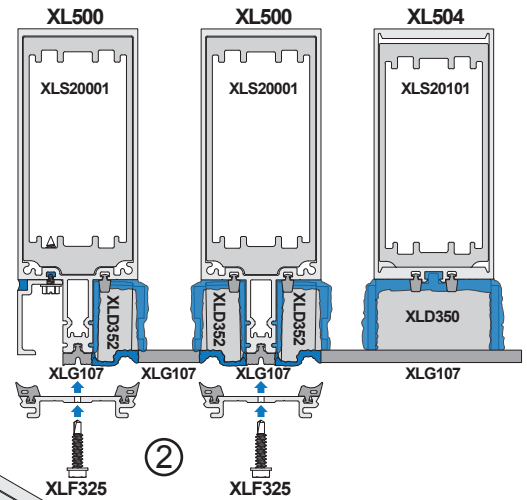
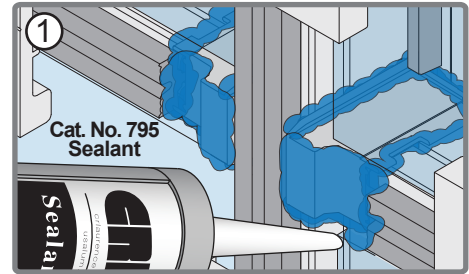

# FACE CAP INSTALLATION

NOTE: See Page 22 for Face Cap fabrication. Install Vertical Face Caps and pin once at Horizontal, then install Horizontals. Orient Weep Holes at bottom.

- ① Install XL110 Vertical Face Cap.  
Using a wood block to protect the cap, apply with Dead Blow Soft Face Hammer. Pin once per length, concealing pin at a horizontal location.
- ② Seal Horizontal Pressure Plates against the Vertical Face Caps.  
Tool sealant into the joint.
- ③ Install Horizontal Face Caps, leaving an equal gap at each end. Make sure that the Weep Hole in the Face Cap is on the bottom.

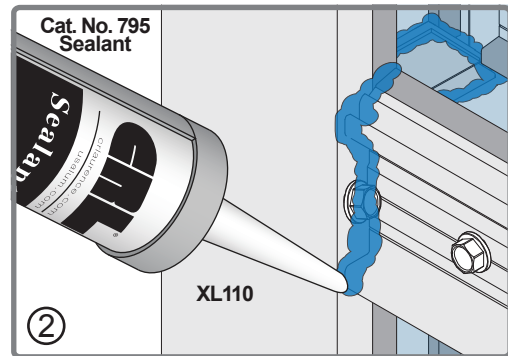
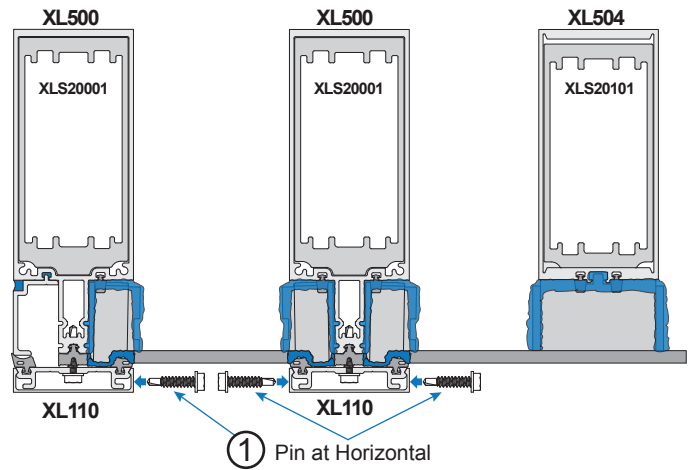
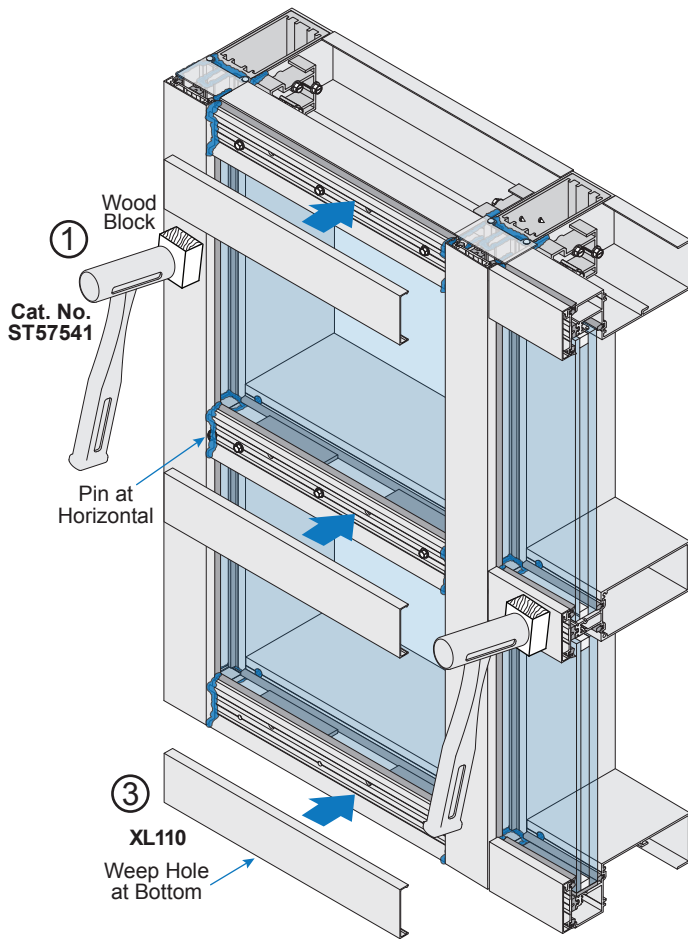

## INTERIOR SEALING FOR WET GLAZED

- ① Clean all silicone surfaces and joints with 50% Isopropyl Alcohol and wipe dry.
- ② Apply Painter's Tape to the mullion and glass as shown.
- ③ Apply Cat. No. 995 Structural Silicone Sealant into pocket between the mullion and the glass starting from the bottom and work towards the top. Be sure to use positive pressure to completely fill pocket and prevent voids in sealant.
- ④ Tool the Structural Sealant smooth immediately after running the bead. Remove Painter's Tape after tooling and before Structural Sealant skins over.

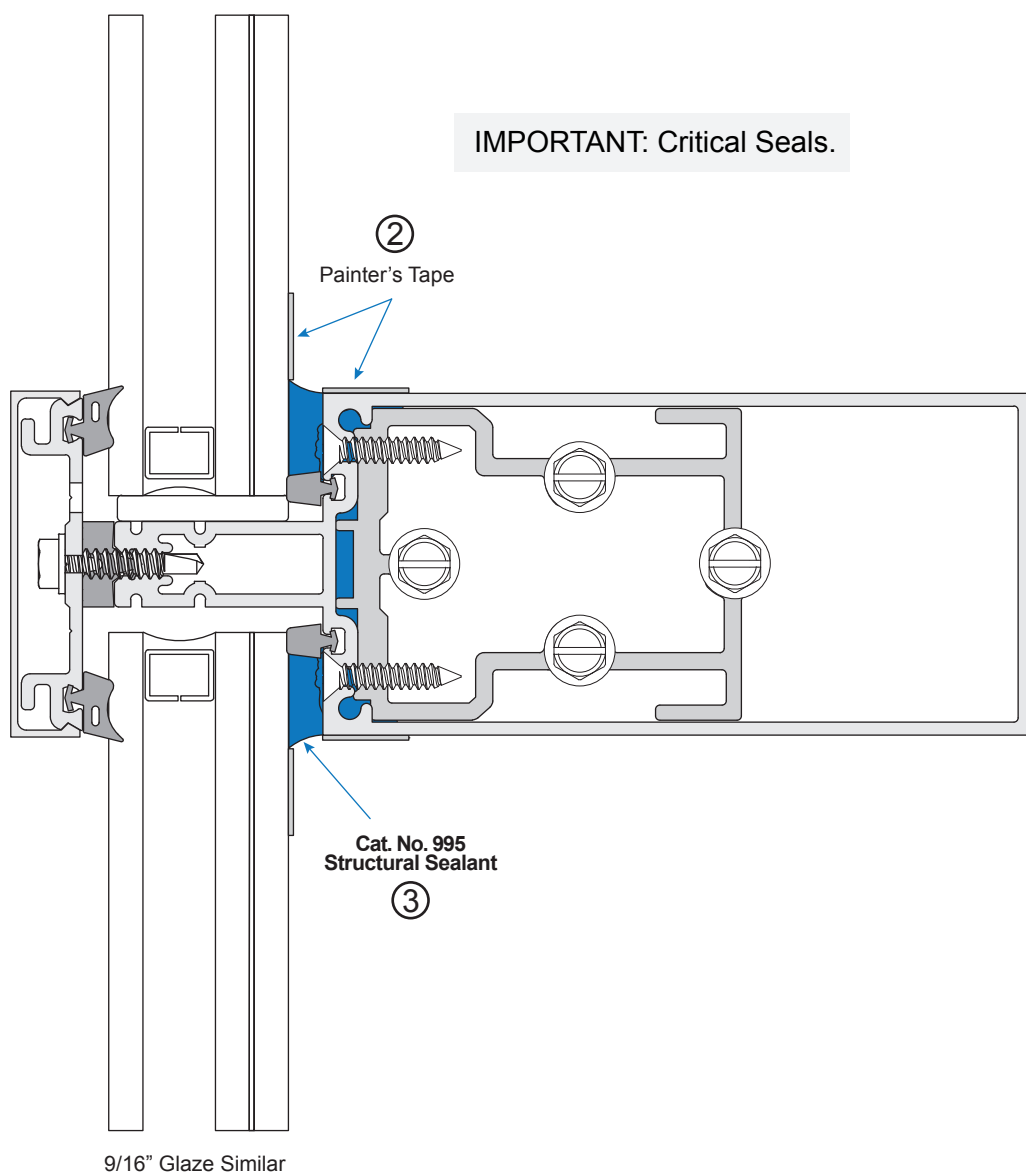

# 90 DEGREE OS CORNER GLASS INSTALLATION

## Captured Corner

NOTE: Follow instructions on Page 33 for Glass Installation. See approved Shop Drawings for actual conditions. Details shown to be used as a guide only.

- ① Seal face of XLD352 End Dam and fill gap between End Dam and Isolator with Cat. No. 795 Silicone Sealant.
- ② Remove Vertical Glazing Retainers. Install Vertical Pressure Plates with 1/8" (3.2) gap at ends. Attach with XLF325 screws 9" (228.6) on center.
- ③ Remove Horizontal Glazing Retainers. Install Horizontal Pressure Plates with Weep Holes at top leaving 1/8" (3.2) gap at ends.
- ④ Torque all XLF325 screws to 90 in-lbs.

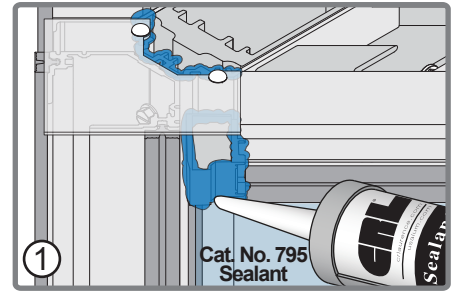

NOTE: See Page 29 for Pressure Plate Installation and Page 30 for Face Cap Installation. Orient Weep Holes at top.

- ⑤ Install XL115 Corner Face Cap and pin at Horizontal.
- ⑥ Seal and tool Horizontal Pressure Plate against XL115 Corner Face Caps and install XL110 Horizontal Face Caps.

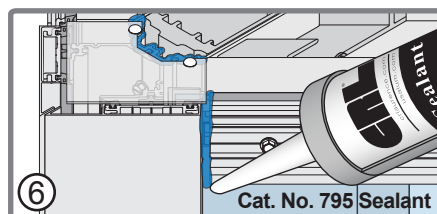
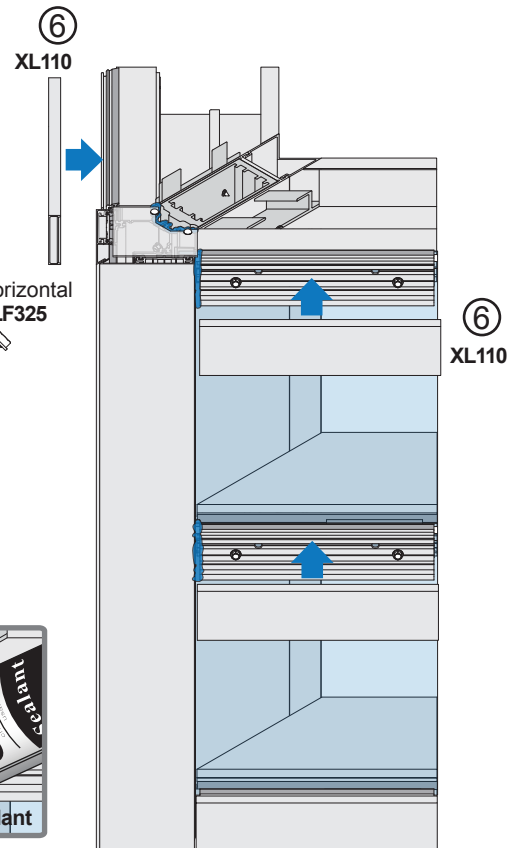
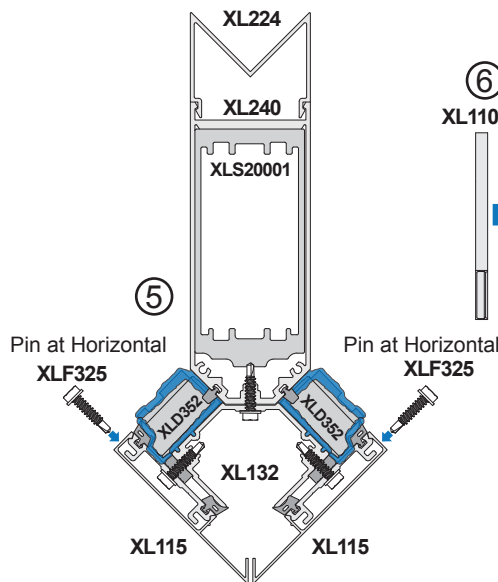
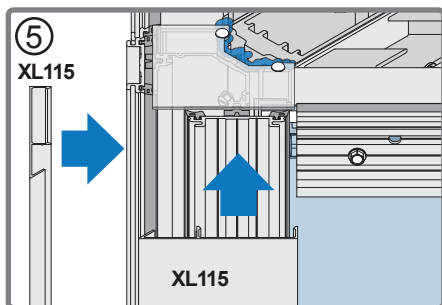
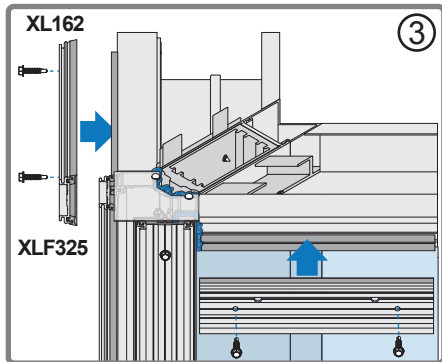
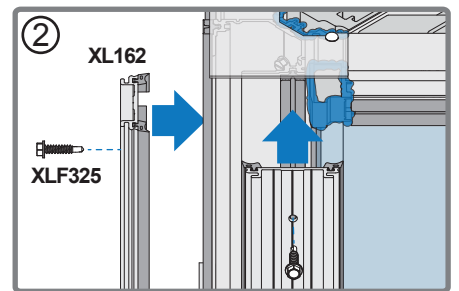

# 90 DEGREE OS CORNER GLASS INSTALLATION (CONTINUED)

## SSG Corner

NOTE: XL132 Pressure Plate is removed after glazing. XLC324 SSG Corner End Dams are installed after that. Follow instructions on Page 33 for Glass Installation.

- ① Apply bead of Cat. No. 995 Structural Silicone Sealant along interior glazing pocket. **IMPORTANT:** Allow for a full cure of Structural Silicone before removing Retainers.
- ② Remove Vertical Glazing Retainers and Pressure Bar.
- ③ Apply Cat. No. 795 Silicone Sealant in vertical race and install XLF64 SSG Corner Tube.
- ④ Install and seal XLC324 SSG Corner End Dams at horizontal members.
- ⑤ Mask off edge of glass and Tube with Painter's Tape and then clean and seal. Tool Structural Sealant smooth immediately after running bead. Remove Tape after tooling and before Structural Sealant skins over.
- ⑥ Remove Horizontal Glazing Retainers. Install Horizontal Pressure Plates with Weep Holes at top leaving 1/8" (3.2) gap at ends. Seal joint with Cat. No. 795 Silicone Sealant.
- ⑦ Install Horizontal Face Caps with Weep Holes at bottom and mitered end at corner. Seal and tool joint with Cat. No. 795 Silicone Sealant.

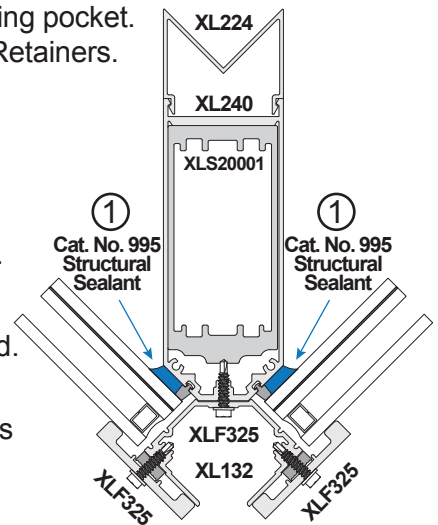

NOTE: See approved Shop Drawings for actual conditions and Pressure Plate and Face Cap dimensions. Details shown to be used as a guide only.

NOTE: Begin Structural Sealant at bottom and work towards top. Use positive pressure to completely fill pocket and prevent voids in sealant.

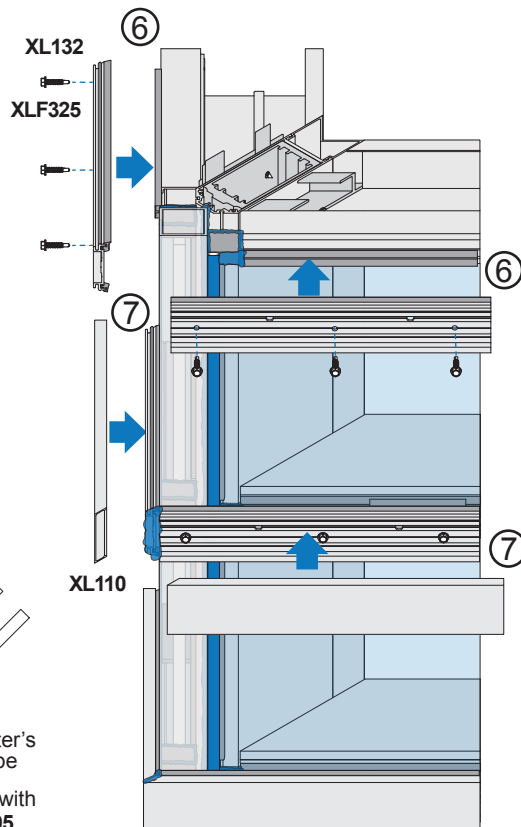
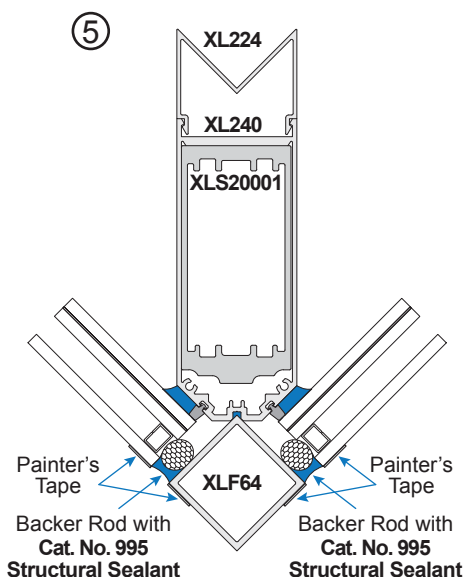
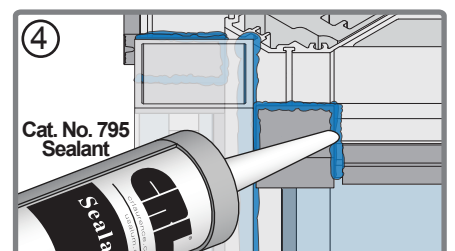
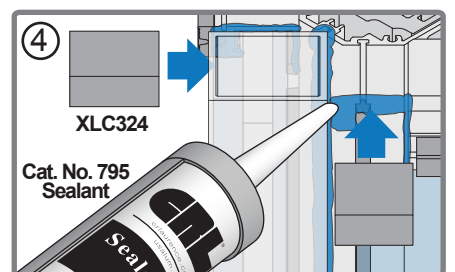
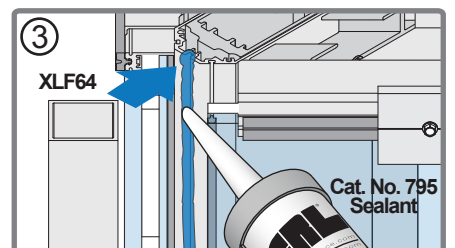
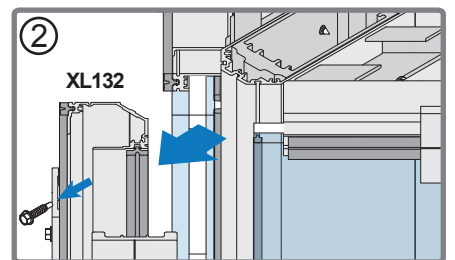

**IMPORTANT:** Critical Seals.

## PRESSURE PLATE AND FACE COVER SPLICING (OPTIONAL)

NOTE: Horizontal Pressure Plate runs continuous over SSG Mullions not to exceed 3 Lites in length. Splice at center of SSG Mullion when needed and pin 1-1/2" (38.1) from ends.

- ① Butt-splice Isolator as required and seal joint with Cat. No. 795 Silicone Sealant.
- ② Install Horizontal Pressure Plates with Weep Holes at top leaving 1/4" (6.4) gap for splice joint at center of SSG Mullion and 1/8" (3.2) gap at ends. Seal joint with Cat. No. 795 Silicone Sealant.
- ③ Torque all XLF325 screws to 90 in-lbs and follow Steps 1-2 on Page 35 to install Vertical Face Caps.
- ④ Install Backer Rod at Pressure Plate splice joint. Install Horizontal Face Caps, leaving a 1/8" (3.2) minimum gap at splice joint and equal gaps at each end. Orient Weep Hole at top.
- ⑤ Seal and tool Face Cap splice joint with Cat. No. 795 Silicone Sealant.

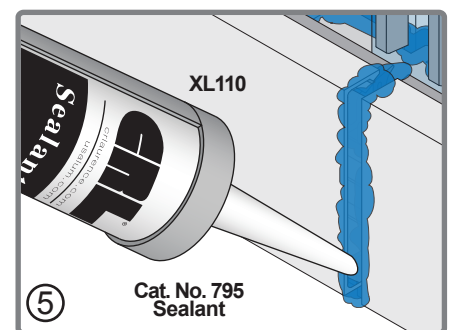
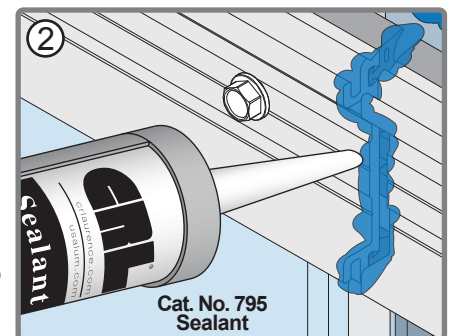
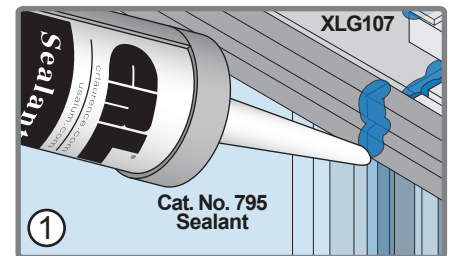
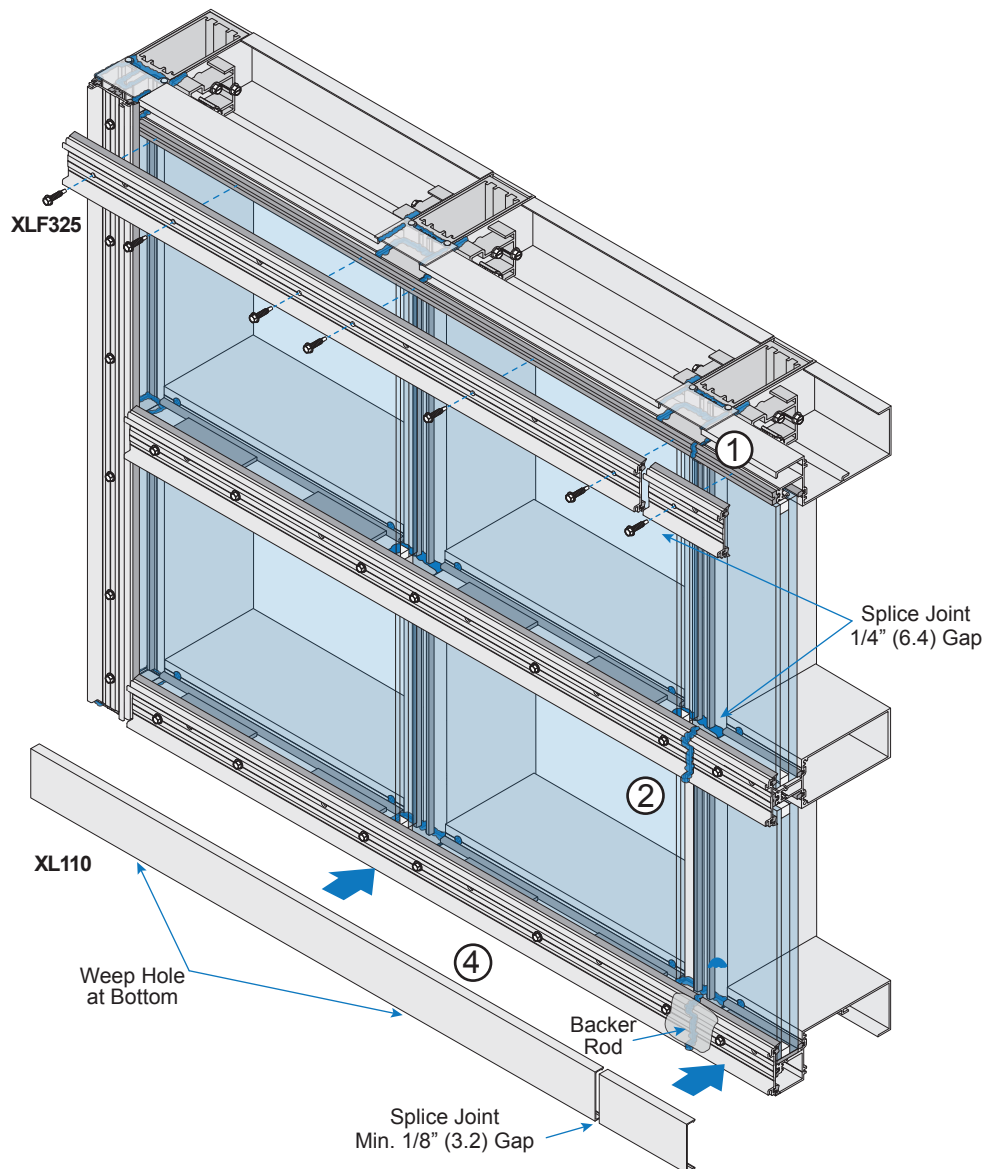

## ENTRANCE DOOR SUBFRAME INSTALLATION

**NOTE:** All Door Subframe Components are shipped fabricated from the factory. The main curtain wall framing can be erected prior to installing the doors.

Curtain Wall Verticals and Door Subframes run through to finished floor. Bed adjacent Curtain Wall Verticals in sealant and anchor to floor per approved Shop Drawings. See Shop Drawings for anchoring Door Jamb Mullion.

- ① Assemble Door Subframe including Threshold.
- ② Install Subframe into Curtain Wall Frame. Shim plumb and true and anchor with XLF322 screws spaced 18" (457.2) on center. Anchor Threshold per Shop Drawings.
- ③ Install Door Stops in Subframe. Vertical Stops run through.
- ④ Mask off Exterior and Interior Subframe Perimeter with Painter's Tape and then clean and seal.
- ⑤ Follow the separate Installation Manual to install door.

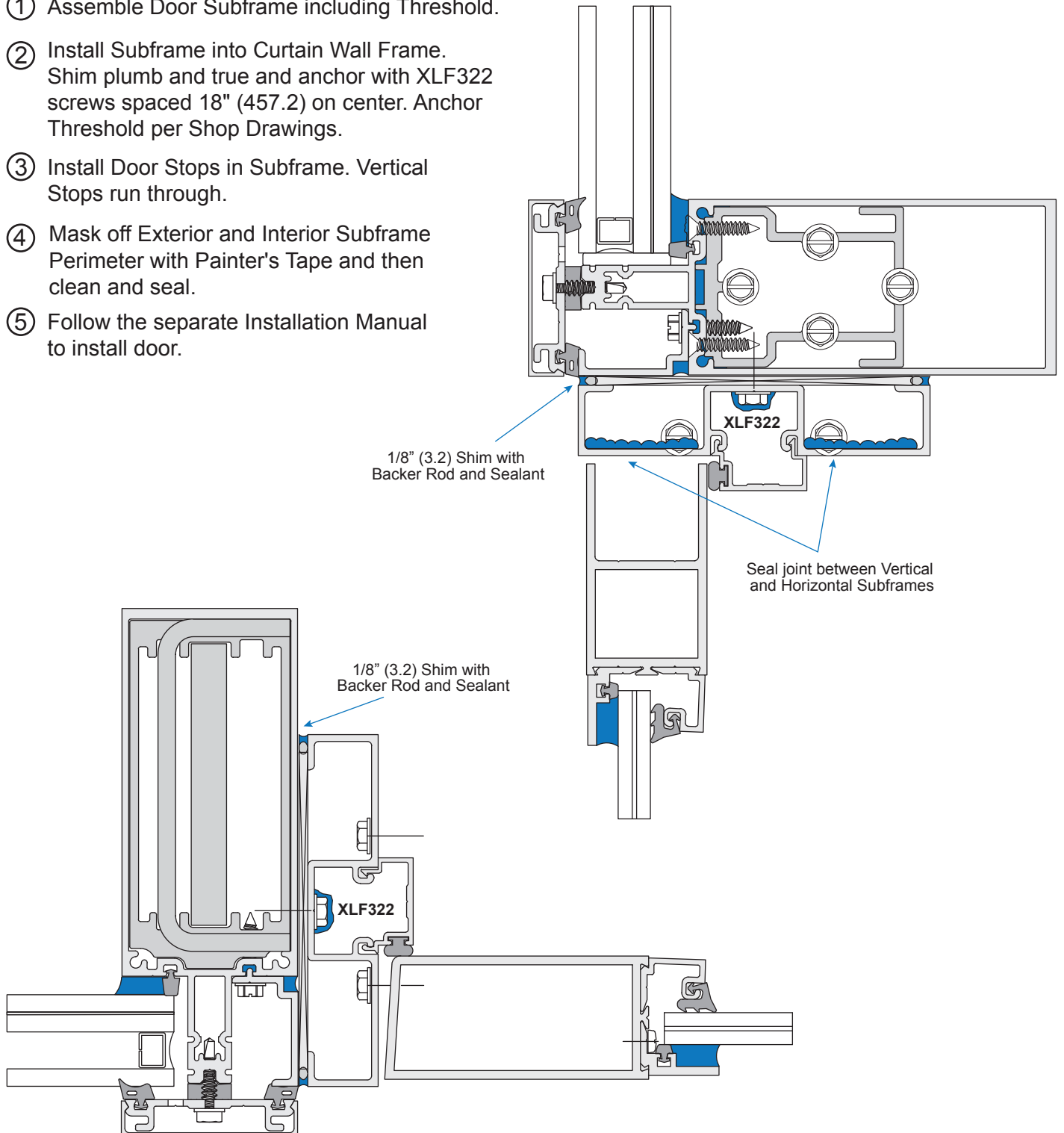



## MID POINT ANCHOR INSTALLATION

NOTE: Details shown are to be used as a guide only.  
See approved Shop Drawings for actual conditions.

### Jamb

- ① Attach Steel Tap Plate to Jamb Mullion with XLF259 screw.
- ② Install plumb and align Vertical Jamb Mullion. Drill appropriate sized holes for Anchor Bolts as shown on approved Shop Drawings.
- ③ Place 1/16" (1.6) minimum Korolath Slip Pad on Tap Plate and install Anchor. Secure with Type F Anchor Bolts.

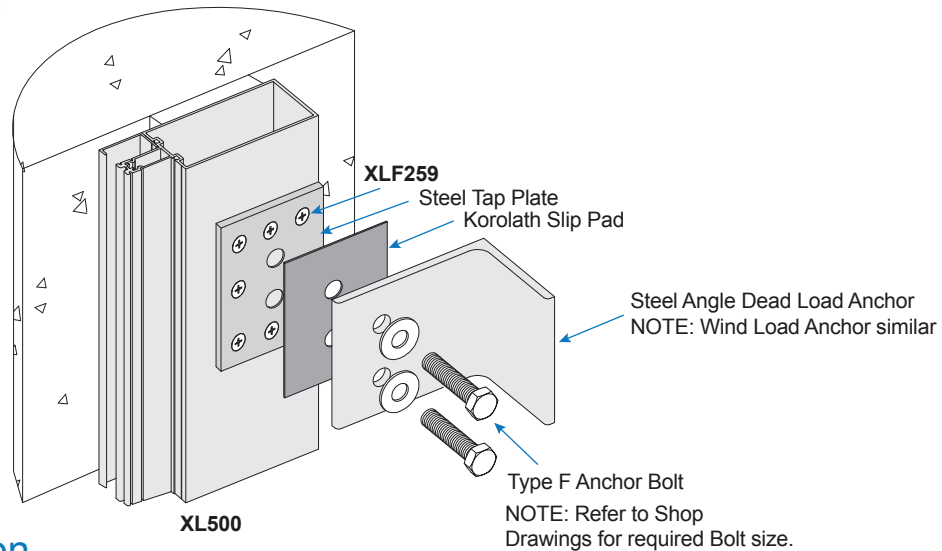

### Intermediate Mullion

- ① Install plumb and align Vertical Mullion. Drill appropriate sized holes for Anchor Bolts as shown on approved Shop Drawings.
- ② Place 1/16" (1.6) minimum Korolath Slip Pad and install Anchors on each side of Mullion.
- ③ Secure with Type F Anchor Bolts, Lock Washers and Nuts as required by Shop Drawings.

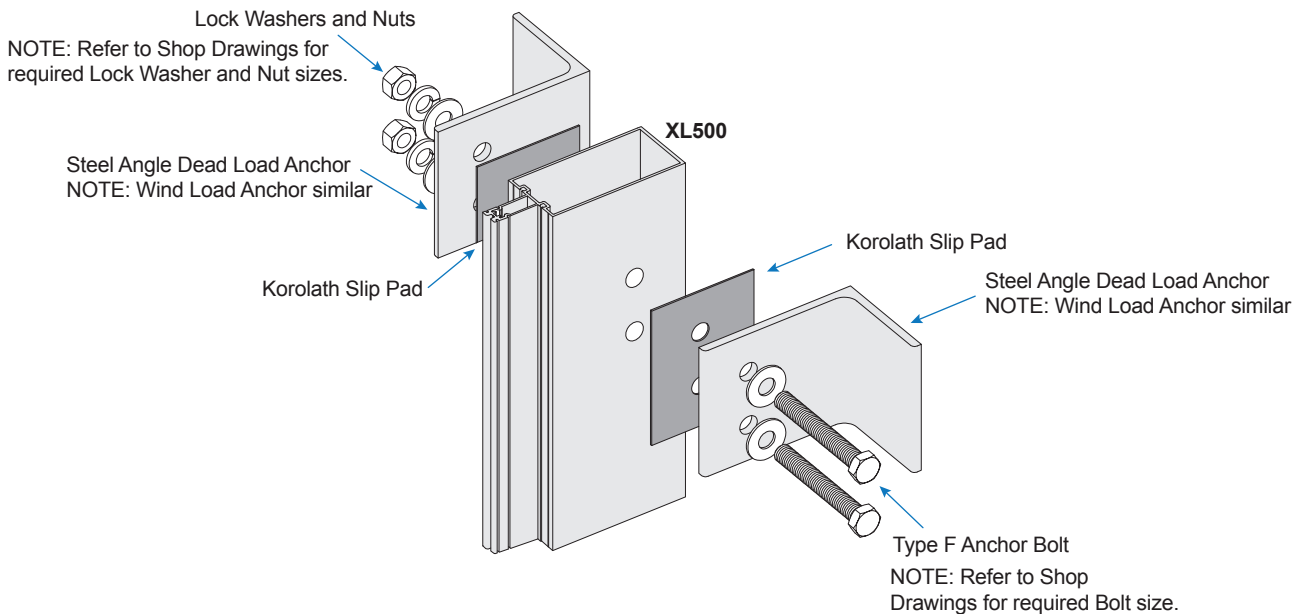

# JAMB AND MULLION SPLICE INSTALLATION

① Attach End Caps and install Bottom Mullion as shown on Page 24.

NOTE: The top of Bottom Mullion is fabricated with XLB18002, XLB18003 or XLB18401 Shear Block and holes to attach Splice Sleeve. Anchor at bottom.

② Apply Bond Breaker Tape to Splice Sleeve.

③ Insert XLF009 Stop Screw into Mullion.

④ Slide Splice Sleeve into top of Mullion and secure with two XLF009 screws on each side.

⑤ Attach End Caps to Top Mullion and slide over top of Splice Sleeve.

⑥ Shim to leave 1-1/4" (31.8) gap between Mullions.

NOTE: Bottom of Top Mullion is fabricated with XLB18002, XLB18003 or XLB18401 Shear Block. Anchor at top.

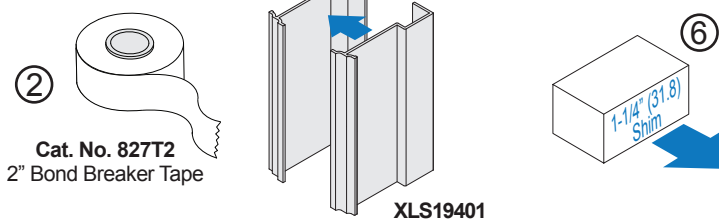
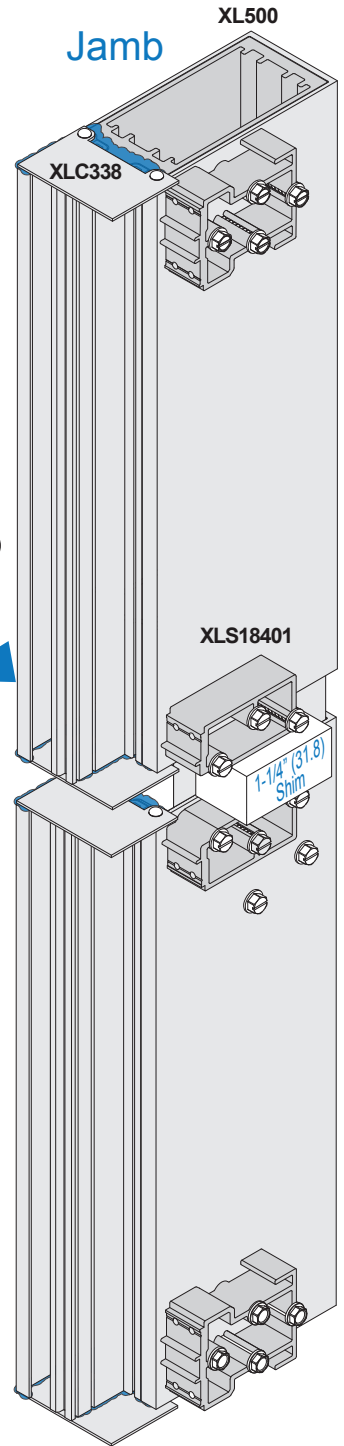

## SSG Mullion

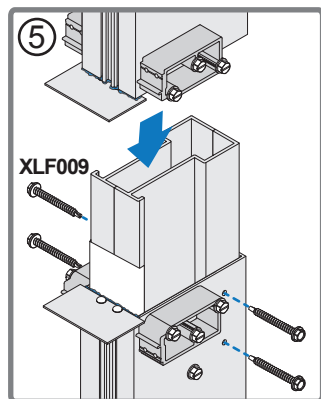
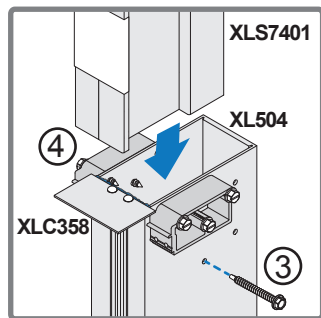
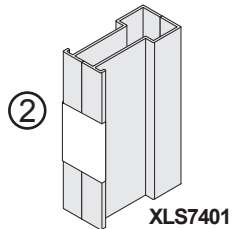

## Corner Mullion

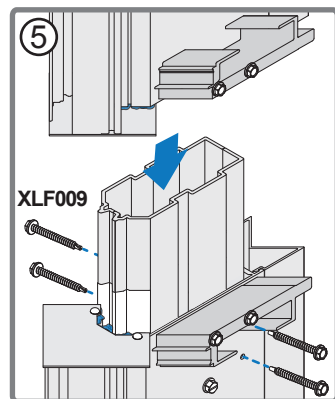
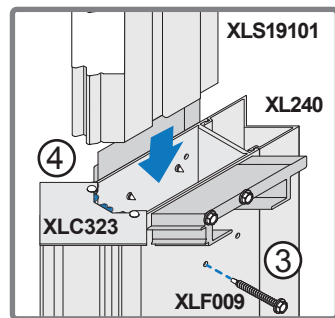
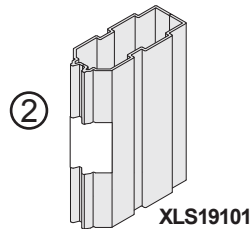

## Intermediate Mullion

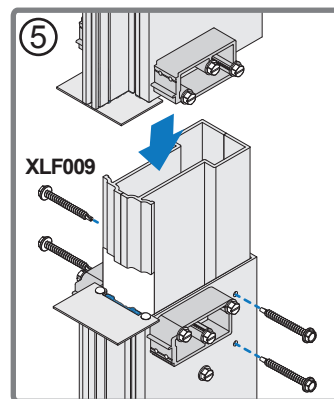
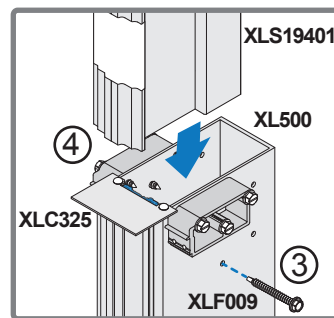
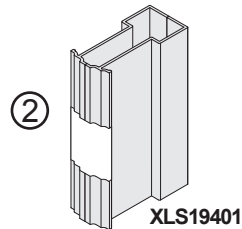

NOTE: Use XLS19401 Splice Sleeve with Jamb.

## STACKED HORIZONTAL INSTALLATION

- ① Note orientation of XL536 Stacked Horizontals and attach to XLB18401 Shear Blocks with XLF118 screw at each end.

Install other Horizontals as shown on Page 25 and continue until Page 32 with Isolator Installation.

NOTE: Remove Shims at Splice Sleeve after Mid Point Anchor is installed. See Page 41.

- ② Install backer rod and Cat. No. 795 Silicone Sealant at Splice Sleeve on interior and exterior. Marry sealant with perimeter seal at Jamb.

- ③ Remove Stop Screw and seal hole.

- ④ Install glass as shown on Page 33.

- ⑤ Install Vertical and then install Horizontal Pressure Plates as shown on Page 34.

NOTE: At Stack Horizontal use XL102 Pressure Plate with XLG117 Gasket at top and XLG160 Gasket at bottom.

- ⑥ Install Vertical and then Horizontal Face Caps as shown on Page 35. Leave 1/4" (6.4) expansion gap at verticals below Stacked Horizontals. Install XL100 Face Cap on XL102 Pressure Plate.

