

# INSTALLATION INSTRUCTIONS

## SERIES 4500 SSG

### WINDOW WALL UNIT GLAZE SYSTEM

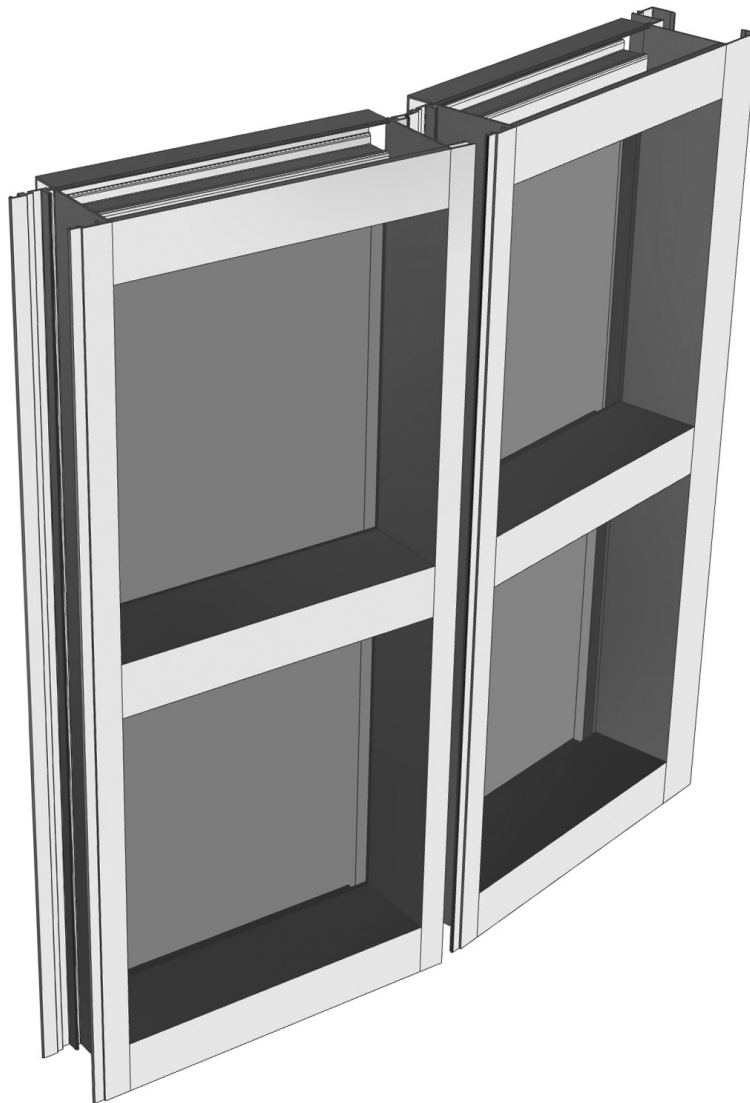

---

Phone: (800) 262-5151 • Fax: (866) 262-3299  
crlaurence.com • usalum.com • crl-arch.com

---

Thank you for your purchase of the C.R. Laurence Co. Inc. Unit Glaze System. It is designed to install easily and efficiently. Please take time to review this manual before you begin.

# HANDLING, STORAGE, AND PROTECTION OF ALUMINUM

The following precautions are recommended to protect the material against damage. Following these precautions will help ensure early acceptance of your products and workmanship.

**A. HANDLE CAREFULLY.**

All aluminum materials at job site must be stored in a safe place, well removed from possible damage by other trades. Cardboard wrapped or paper interleaved materials must be kept dry.

**B. CHECK ARRIVING MATERIALS.**

Check for quantity counts and keep records of where various materials are stored.

**C. KEEP MATERIALS AWAY FROM WATER, MUD, AND SPRAY.**

Prevent cement, plaster, or other materials from damaging the finish.

**D. PROTECT THE MATERIALS AFTER ERECTION.**

Protect erected frame with polyethylene or canvas splatter screen. Cement, plaster, terrazzo, other alkaline solutions, and acid based materials used to clean masonry are harmful to the finish. If any of these materials come in contact with the aluminum, immediately remove with water and mild soap.

The rapidly changing technology within the architectural aluminum products industry demands that U.S. Aluminum reserve the right to revise, discontinue or change any product line, specification or electronic media without prior written notice.

**NOTE:** Dimensions in parentheses ( ) are millimeters unless otherwise noted.

# GENERAL INSTALLATION NOTES

## Recommended guidelines for all installations:

- 1. REVIEW CONTRACT DOCUMENTS.** Check shop drawings, installation instructions, architectural drawings and shipping lists to become thoroughly familiar with the project. The shop drawings take precedence and include specific details for the project. Note any **field verified** notes on the shop drawings prior to installing. The installation instructions are of a general nature and cover most conditions.
- 2. INSTALLATION.** All materials are to be installed plumb, level, and true.
- 3. BENCH MARKS.** All work should start from bench marks and/or column lines as established by the architectural drawings and the general contractor with guaranteed accuracy. Working from these datum points and lines determine:
  - a) The plane of the wall in reference to offset lines provided on each floor.
  - b) The finish floor lines in reference to bench marks on the outer building columns.
  - c) Mullion spacing from both ends of masonry opening to prevent dimensional build-up of daylight opening.
- 4. FIELD WELDING.** All field welding must be adequately shielded to avoid any splatter on glass or aluminum. Results will be unsightly and/or structurally unsound. Advise general contractor and other trades accordingly. All field welds of steel anchors must receive touch-up paint (zinc chromate) to avoid rust.
- 5. SURROUNDING CONDITIONS.** Make certain that construction which will receive your materials is in accordance with the contract documents. If not, notify the general contractor in writing and resolve differences before proceeding with work.
- 6. ISOLATION OF ALUMINUM.** Aluminum to be placed in direct contact with uncured masonry or incompatible materials should be isolated with a heavy coat of zinc chromate or bituminous paint.
- 7. SEALANTS.** Sealants must be compatible with all materials with which they have contact with (full or incidental), including other sealant surfaces. It is the sole responsibility of the glass company to consult the sealant manufacturer for recommendations regarding joint size, shelf life, compatibility, cleaning, priming, tooling, adhesion, etc. It is the responsibility of the **Glazing Contractor** to submit a statement from the sealant manufacturer indicating that glass and glazing materials have been tested for compatibility and adhesion with glazing sealants, and interpreting test results relative to material performance, including recommendations for primers and substrate preparation required to obtain adhesion. The chemical compatibility of all glazing materials and framing sealants with each other and with like materials used in glass fabrication must be established. **This is required on every project.**
- 8. FASTENING.** Within the body of these instructions "fastening" means any method of securing one part to another or to adjacent materials. Only those fasteners used within the system are specified in these instructions. Due to the varying perimeter conditions and performance requirements, perimeter and anchor fasteners are not specified in these instructions. For perimeter and anchor fasteners refer to the shop drawings or consult the fastener supplier.
- 9. BUILDING CODES.** Due to the diversity in state/provincial, local, and federal laws and codes that govern the design and application of architectural products, it is the responsibility of the individual architect, owner, and installer to assure that products selected for use on projects comply with all the applicable building codes and laws. U. S. Aluminum exercises no control over the use or application of its products, glazing materials, and operating hardware, and assumes no responsibility thereof.
- 10. EXPANSION JOINTS.** Expansion joints and perimeter seals shown in these instructions and in the shop drawings are shown at normal size. Actual dimensions may vary due to perimeter conditions and/or difference in metal temperature between the time of fabrication and the time of installation. Gaps between expansion members should be based on temperature at time of installation.
- 11. WATER HOSE TEST.** As soon as a representative amount of the wall has been glazed (500 square feet or 46.5 m<sup>2</sup>) a water hose test should be conducted in accordance with AAMA 502-08 specifications to check the installation. On all jobs the hose test should be repeated every 500 square feet (46.5 m<sup>2</sup>) during the glazing operation.
- 12. COORDINATION WITH OTHER TRADES.** Coordinate with the general contractor any sequence with other trades which offset curtain wall installation (i.e. fire proofing, back-up walls, partitions, ceilings, mechanical ducts, converters, etc.).
- 13. CARE AND MAINTENANCE.** Final cleaning of exposed aluminum surfaces should be done in accordance with AAMA 609.1 for anodized aluminum and 610.1 for painted aluminum.

# ORDER OF ASSEMBLY AND INSTALLATION

GENERAL INSTALLATION NOTES.....	03
PRODUCT DESCRIPTION .....	05
PARTS LIST .....	06
FABRICATION.....	07 - 09
CUT SIZE CALCULATIONS.....	07
DRILLING ATTACHMENT HOLES.....	08
INSTALLING TW700 STIFFENER CLIPS.....	08
FABRICATE SILL WEEP HOLES.....	09
FABRICATE TW703 WEEP HOLES .....	09
FABRICATE HORIZONTAL FACE CAP WEEP HOLES .....	09
ASSEMBLY.....	10 - 19
FRAME MEMBER CONNECTION.....	10
FRAME SEALING .....	11
FILLER PLATE ATTACHMENT .....	11
WATER DEFLECTORS (ONLY AT JAMBS).....	12
SETTING BLOCKS .....	13
GASKET INSTALLATION (FACE CAPS).....	14
GASKET INSTALLATION (FRAME) .....	15
GLAZING END SECTIONS .....	16
GLAZING INTERMEDIATE SECTIONS .....	17
INSTALLING FACE CAP CLIPS .....	18
FACE COVER INSTALLATION .....	18
VERTICAL FACE CAP INSTALLATION.....	19
HORIZONTAL FACE CAP INSTALLATION .....	19
INSTALLATION.....	20 - 25
SUBSILL END DAMS .....	20
SUBSILL INSTALLATION .....	20 - 21
HEAD ANCHORS.....	22
INSERTING THE PANELS .....	23
FASTEN HEAD ANCHORS .....	24
SEAL END JAMB .....	24
SEALING THE SUBSILL .....	25
FINAL SEALING .....	25
GUIDE TO SEALANTS .....	26

# PRODUCT DESCRIPTION

## ABOUT THE SSG UNIT GLAZE SYSTEM

This Installation Manual covers the general procedures required for the Unit Glaze System. Please review it thoroughly before starting your installation. Each fully glazed panel is fabricated to specifications in the shop rather than on the job site. This gives the contractor access to in-house equipment and fixtures not available in the field. It also provides a cleaner and safer environment for fabrication and inspection. Once the Unit Glaze panels are complete they are easily transported to the job where they are positioned and snapped into place. After installation they are sealed to the structure.

### TOP VIEW

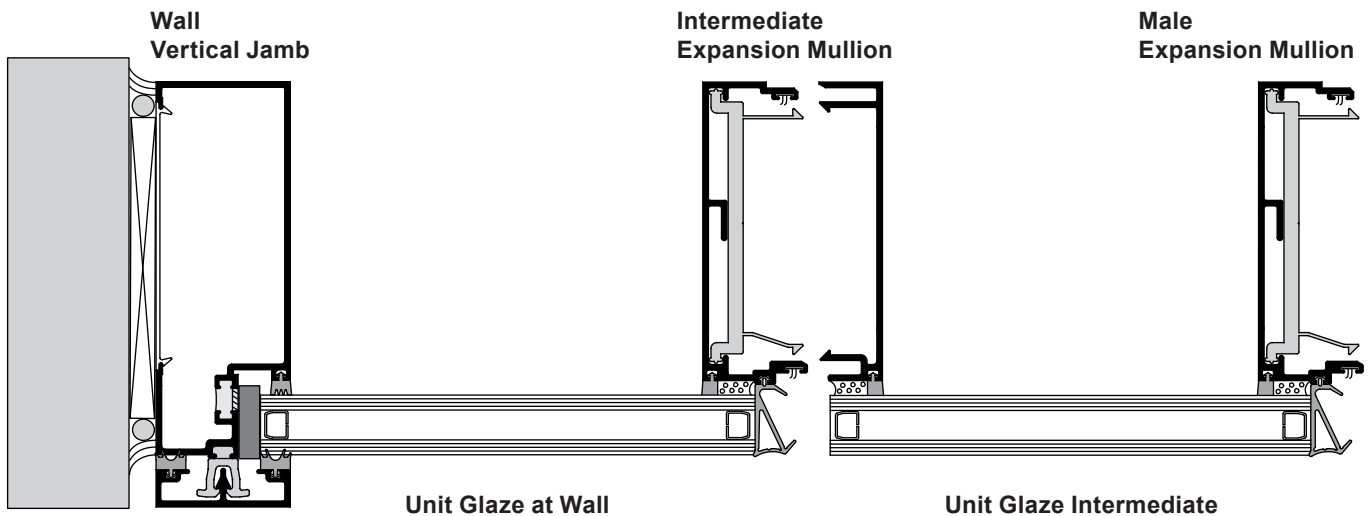









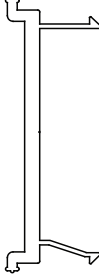
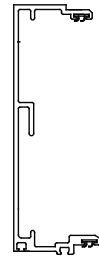

### DETAIL A

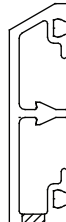
Frames may be shop fabricated and shipped to job site partially or totally assembled. Systems feature screw race joinery and allow for interior or exterior assembly. Frames are fabricated in units and snapped together. Each unit must have at least one vertical deep pocket to allow for glazing. Plan units accordingly. **See DETAIL A.** Never allow two shallow pockets to face each other.

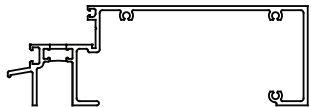
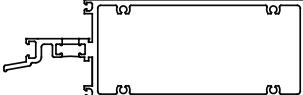
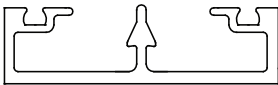
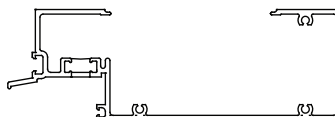
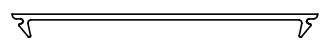
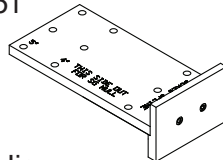
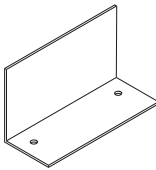
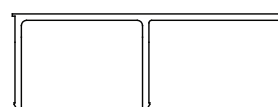
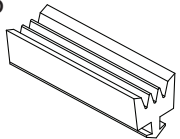
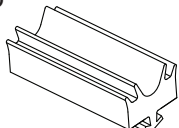
**SERIES 4500 UNIT GLAZE SYSTEM**

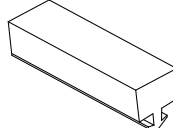
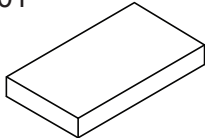
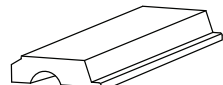
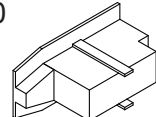
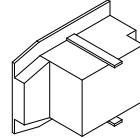
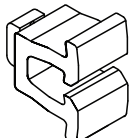
**PARTS LIST**

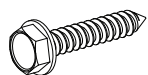
<p>TW718</p>  <p>Mullion</p>	<p>PS145</p>  <p>Jamb Filler</p>	<p>TW700</p>  <p>Stiffener Clip</p>	<p>TW770</p>  <p>Male Vertical Mullion</p>
<p>TW771</p>  <p>Female Vertical Mullion</p>	<p>TW917</p>  <p>Horizontal Face Cap</p>	<p>TW703</p>  <p>Sub Sill</p>	<p>TW747</p>  <p>Sill</p>
<p>TW728</p>  <p>Horizontal Mullion</p>	<p>TW912</p>  <p>Vertical Face Cap</p>	<p>TW744</p>  <p>Head</p>	<p>PV100</p>  <p>PVC Flush Insert - Optional</p>
<p>DJ751</p>  <p>Drill Jig</p>	<p>EC680</p>  <p>End Dam</p>	<p>HC751</p>  <p>Head Anchor</p>	<p>NP716</p>  <p>Interior Sponge Gasket</p>
<p>NP726</p>  <p>Exterior Dense Gasket</p>	<p>VS302000012</p>  <p>Weather Gasket</p>	<p>SP250</p>  <p>Silicone Spacer Gasket</p>	<p>WB701</p>  <p>Edge Block</p>
<p>SB710</p>  <p>Setting Block</p>	<p>WD710</p>  <p>Water Deflector</p>	<p>WD711</p>  <p>Water Deflector</p>	<p>NC900</p>  <p>Face Cap Retainer Clip</p>
<p>8X12PHPSMS</p>  <p>8 x 1/2" Pan Head Phillips Sheet Metal Screw</p>	<p>ST251</p>  <p>#10 x 1" Hex Head Washer Screw</p>		

# FABRICATION

## CUT SIZE CALCULATIONS

Measure ROUGH OPENING to determine FRAME DIMENSION. Allow a minimum clearance of 1-1/2" (38.1) at header and 1-1/2" (38.1) at wall jambs and subsill. Extra clearances may be necessary to accommodate building tolerances.

Cut members to size

- Subsill:** Overall FRAME WIDTH PLUS 1" (25.4). Subsill must extend 1" (25.4) outside of last wall jamb to allow last panel installation. Subsill runs through. If opening exceeds 24' (7.32 m) in width splice sleeves must be used at splice joints. If entrances occur subsill should butt against door jambs.
- Verticals:** FRAME HEIGHT MINUS 5/16" (7.9). Verticals run through.
- Horizontals:** DAYLIGHT OPENING. Horizontals run between verticals. Cut horizontal glazing beads 1/32" (0.8) undersize for easier installation.
- Vertical Trims:** FRAME HEIGHT MINUS 5/16" (7.9). Verticals run through.
- Horizontal Trims:** END HORIZONTALS: Daylight Opening plus 1-1/16" (27).  
CENTER HORIZONTALS: Daylight Opening plus 2-1/8" (54).

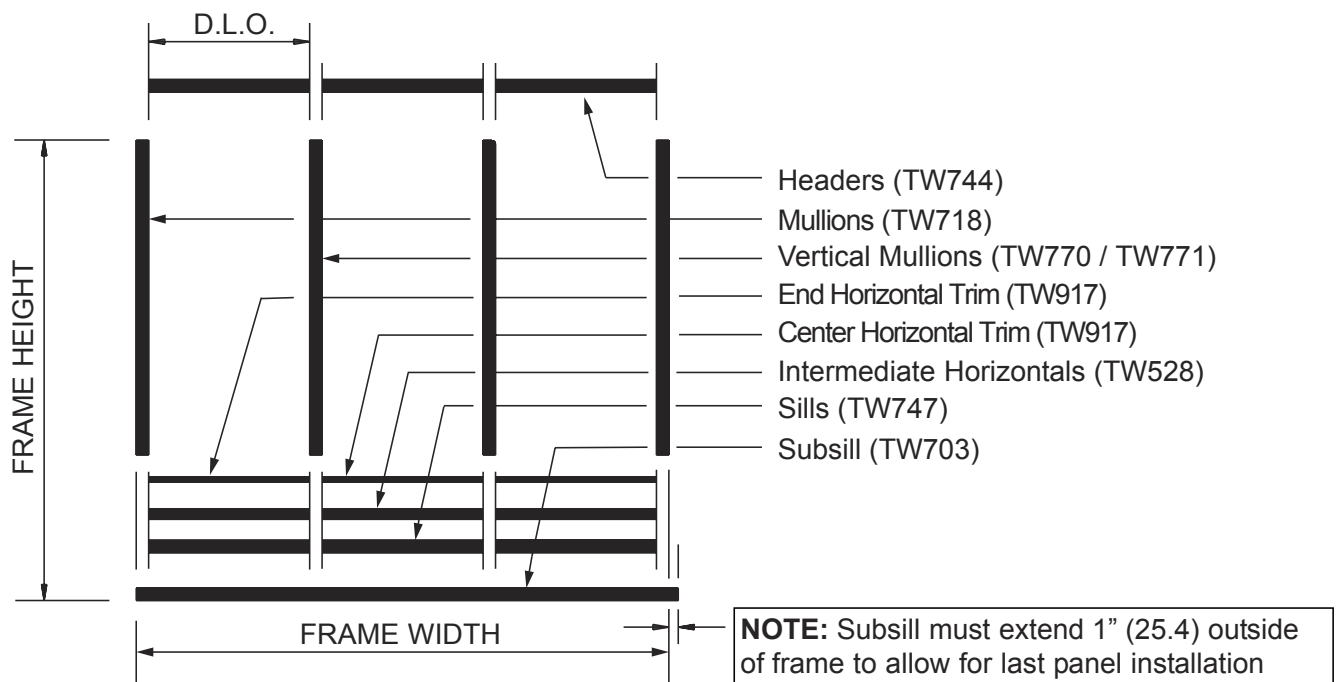

DETAIL B

# FABRICATION

## DRILLING ATTACHMENT HOLES

Mark the location of horizontals in vertical members and drill holes for assembly screws. The use of drill jigs is recommended. Place jig over glazing edge.

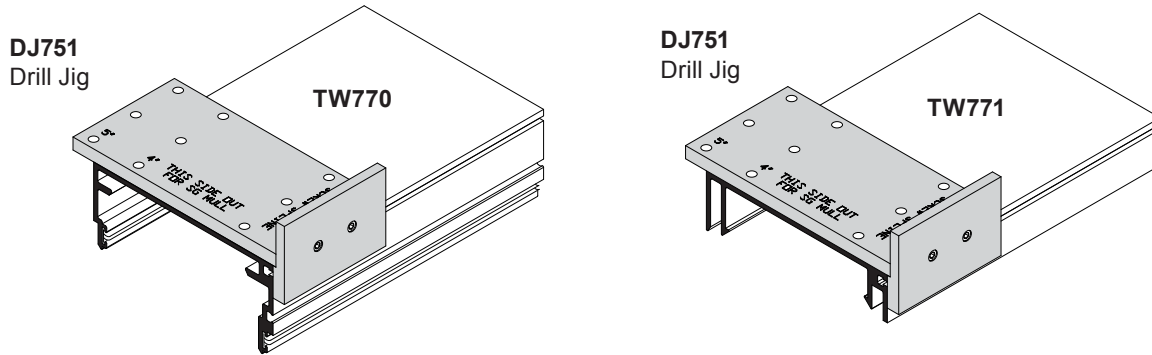

DETAIL C

Drill .201" (5.1) holes (#7 drill) as shown

## INSTALLING TW700 STIFFENER CLIPS

Slide the TW700 Stiffener Clip into TW770 split mullion. Position clips and stake in place.

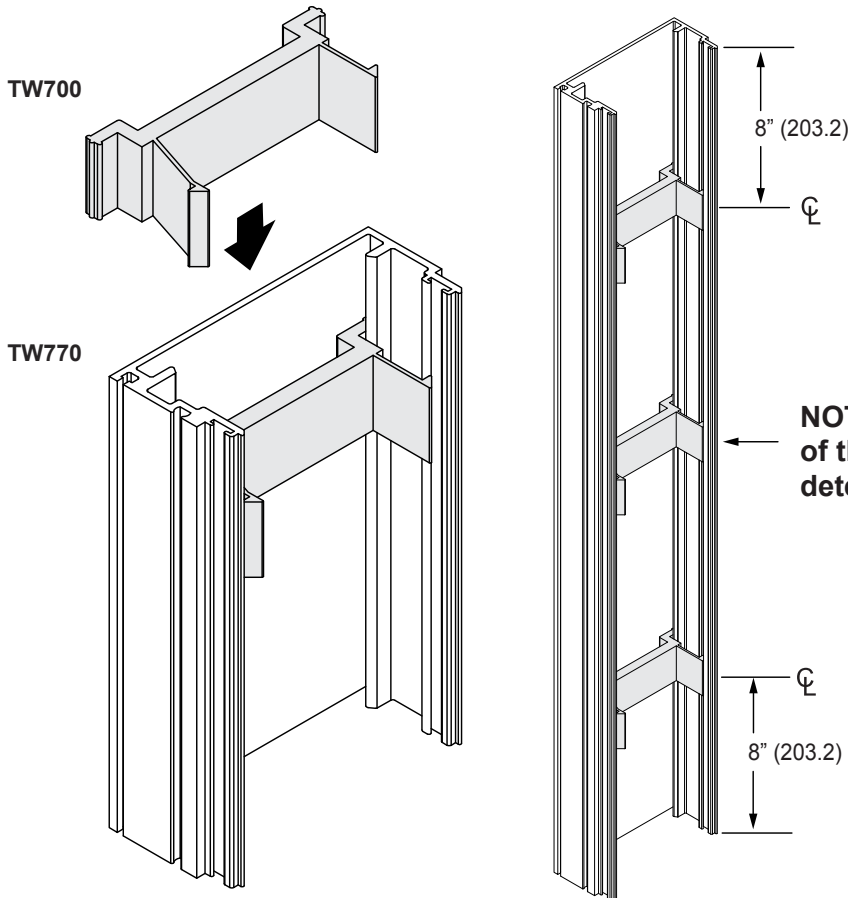

**NOTE:** The length, quantity and spacing of the TW700 Stiffener Clips **MUST** be determined by a qualified engineer.

DETAIL D



# FABRICATION

## FABRICATE SILL WEEP HOLES

Fabricate one 2" (50.8) weep hole 6" (152.4) from each end of all sills.

NOTE: One weep hole each end of all sills.

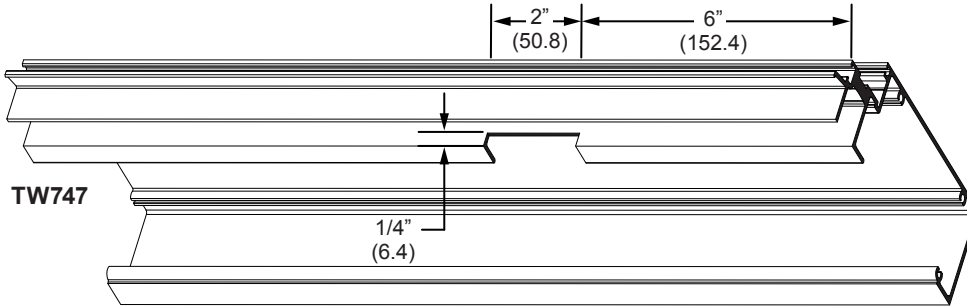

DETAIL E

## FABRICATE TW703 WEEP HOLES

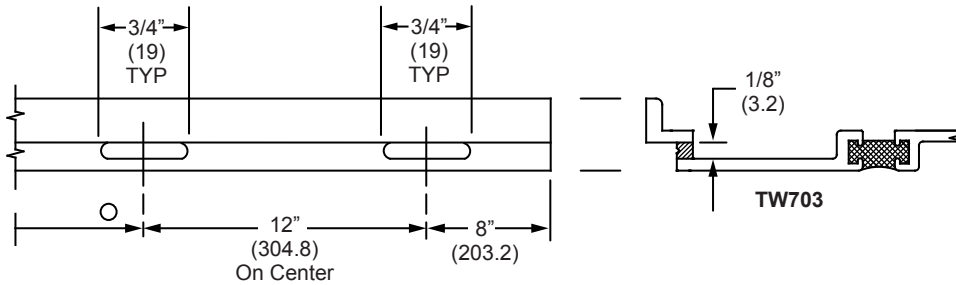

DETAIL F

## FABRICATE HORIZONTAL FACE CAP WEEP HOLES

NOTE: One weep hole each end of all horizontal face caps. See DETAIL G.

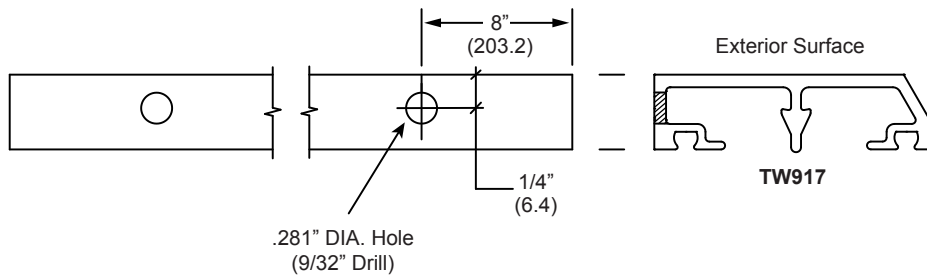

DETAIL G

# ASSEMBLY

## FRAME MEMBER CONNECTION

Apply silicone to ends of horizontal members and assemble panels using screws provided.

Tool excess silicone.

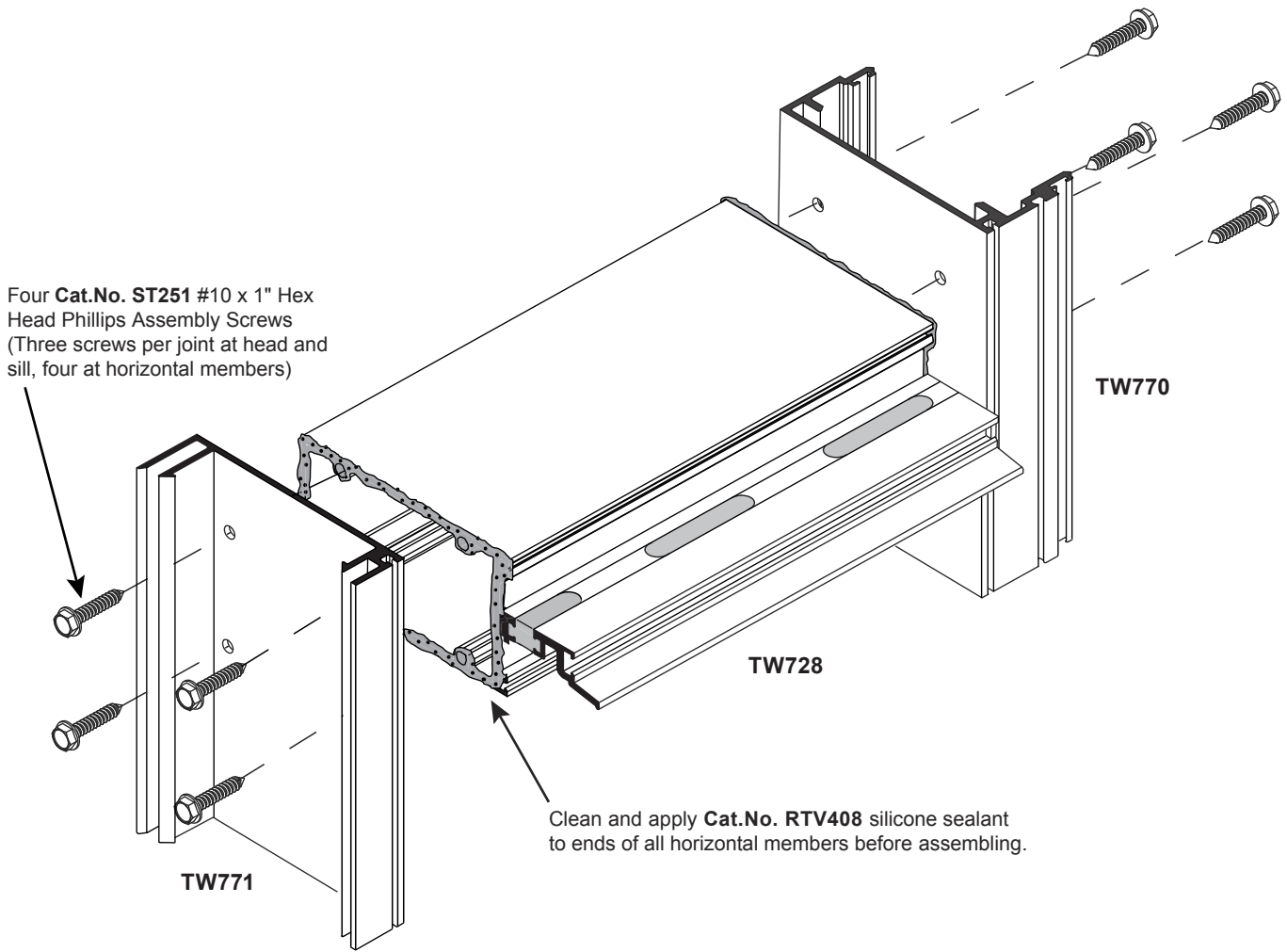

DETAIL H

# ASSEMBLY

## FRAME SEALING

After panels are assembled apply bead of silicone to joint between verticals, horizontals, head and sill members from underside, including over all screw threads to ensure a watertight installation.

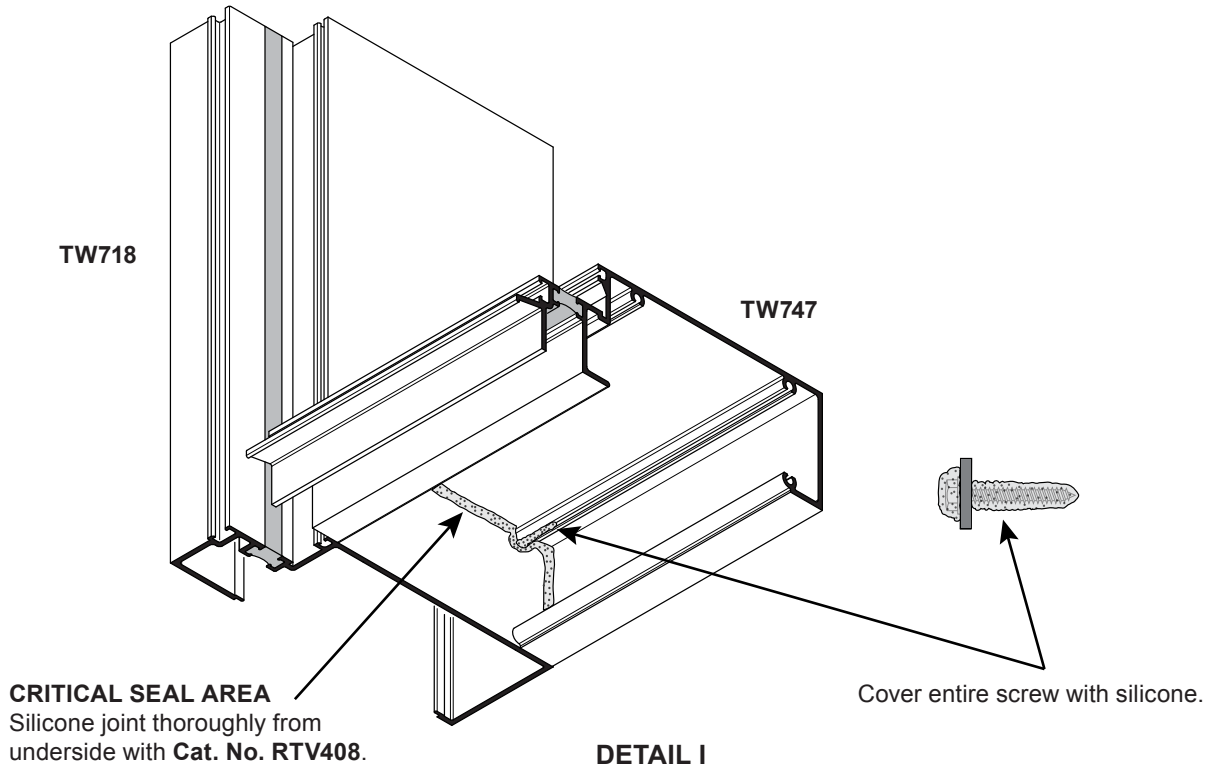

## FILLER PLATE ATTACHMENT

Apply **Cat. No. RTV408** Silicone Sealant on jamb before snapping jamb fillers to back of wall jamb.

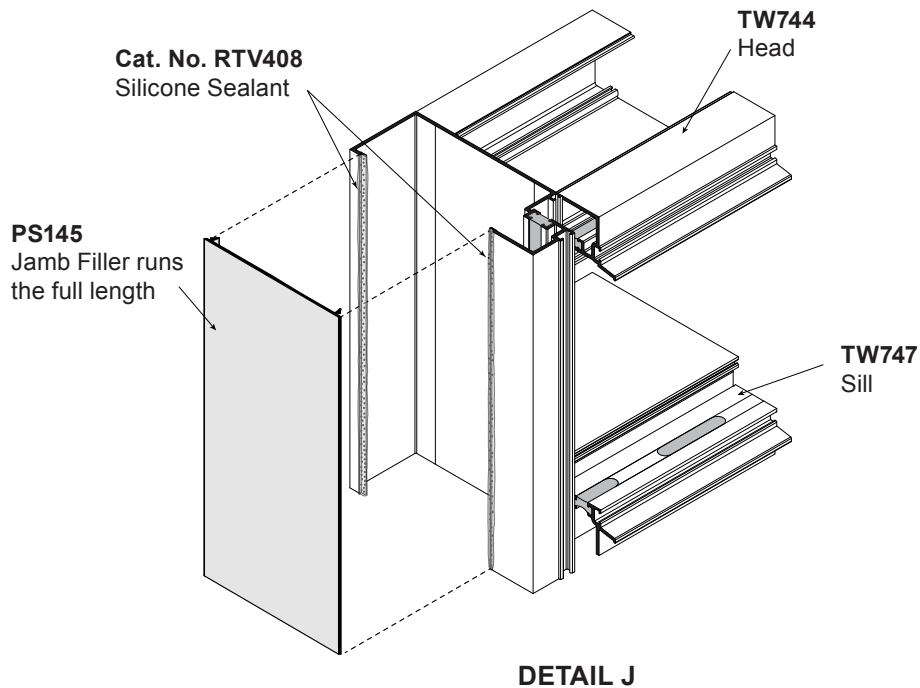

# ASSEMBLY

## WATER DEFLECTORS (ONLY AT JAMBS)

Apply silicone to vertical glazing pocket and gasket reglet at vertical/horizontal intersection. Silicone must be applied to two sides of pocket only. Clearance at exterior side will allow infiltrated water to run down to subsill. See **DETAIL K**.

Insert water deflector into glazing pocket and slide it down into position. See **DETAIL L**. Top of deflector must be flush with horizontal glazing pocket.

**NOTE:** Water deflectors applied to door jambs must be sealed all around to prevent water from running to floor (Water will drain at opposite end).

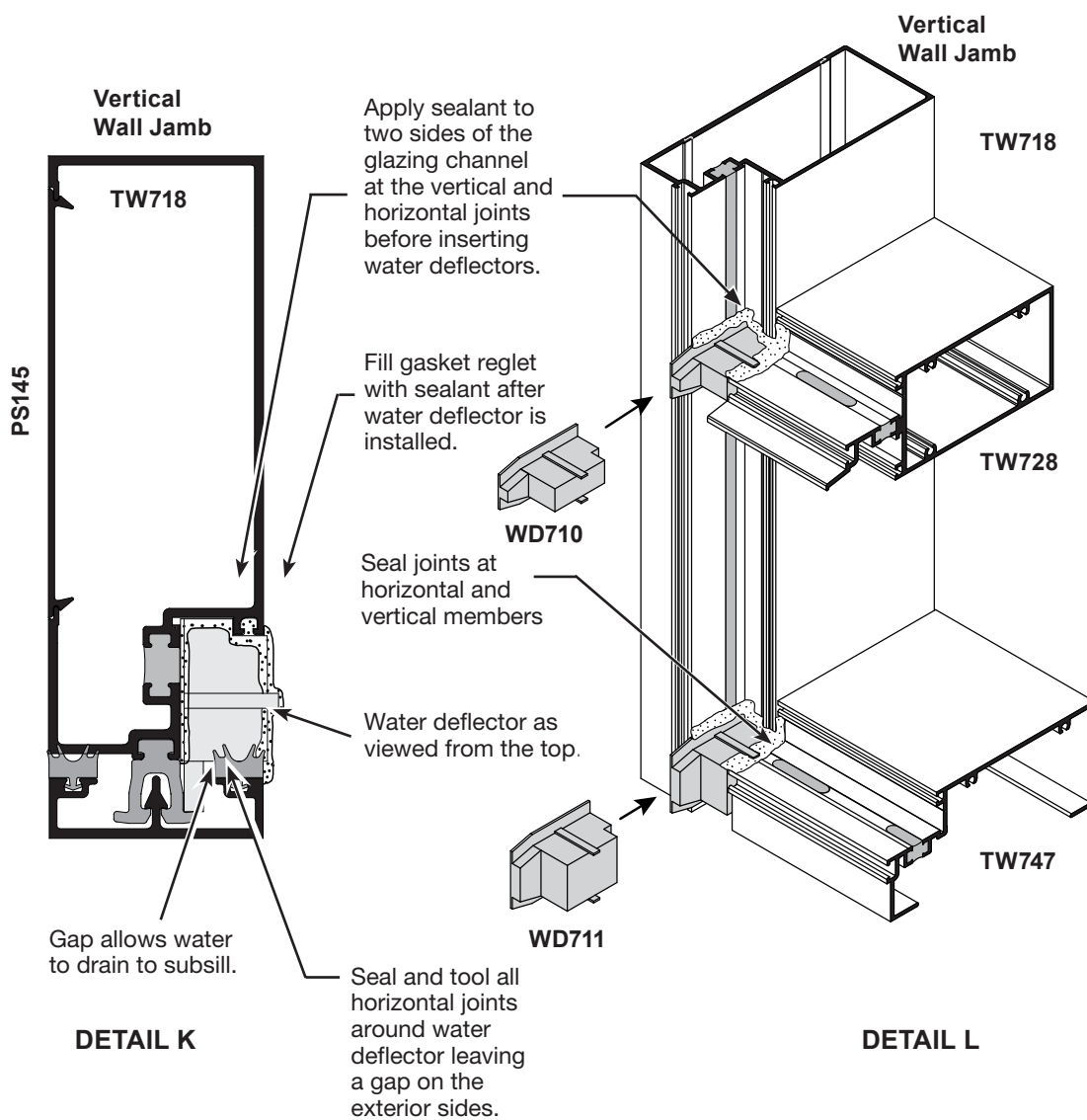

# ASSEMBLY

## SETTING BLOCKS

Locate two setting blocks at quarter points or eighth points as shown on approved shop drawings.

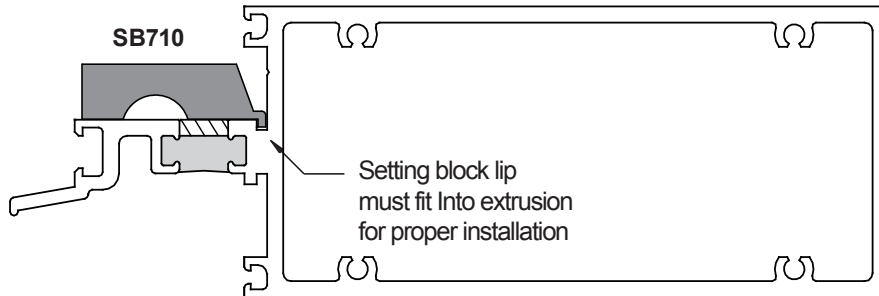

DETAIL M

Peel off paper backing from edge blocks and locate one on each vertical at mid-points of the glass height.

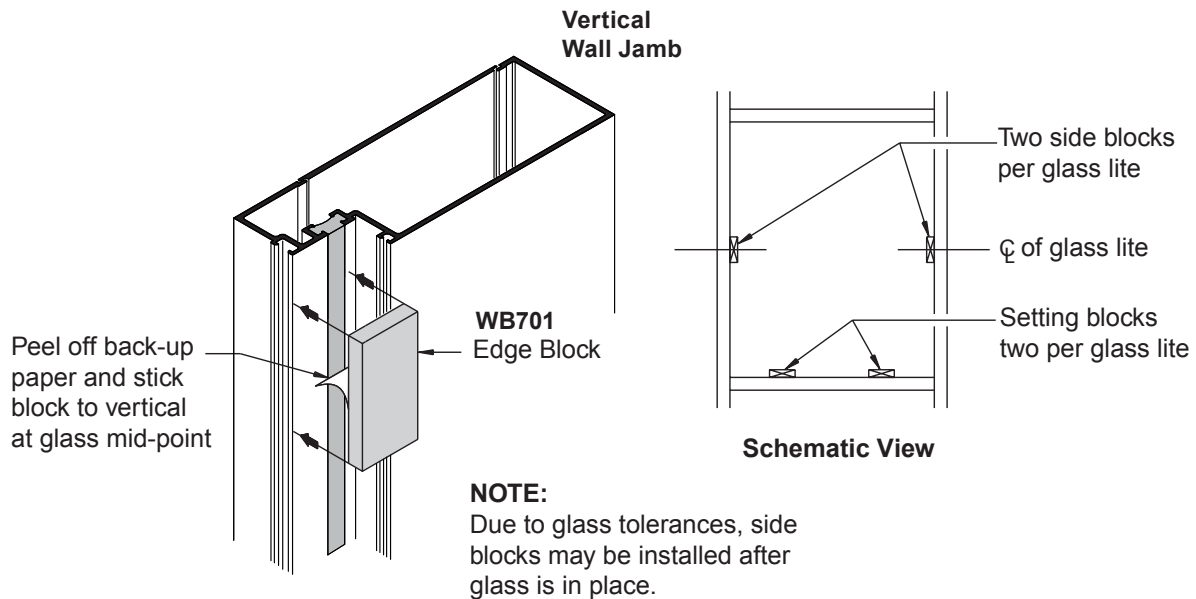

**NOTE:**  
Due to glass tolerances, side blocks may be installed after glass is in place.

DETAIL N

# ASSEMBLY

## GASKET INSTALLATION (FACE CAPS)

NP726 EPDM Exterior Dense gasket is used on all Face Caps. Vertical face gaskets run continuous and should be cut 1" (25.4) long on each end to allow for shrinkage

### Horizontal Trim Plates

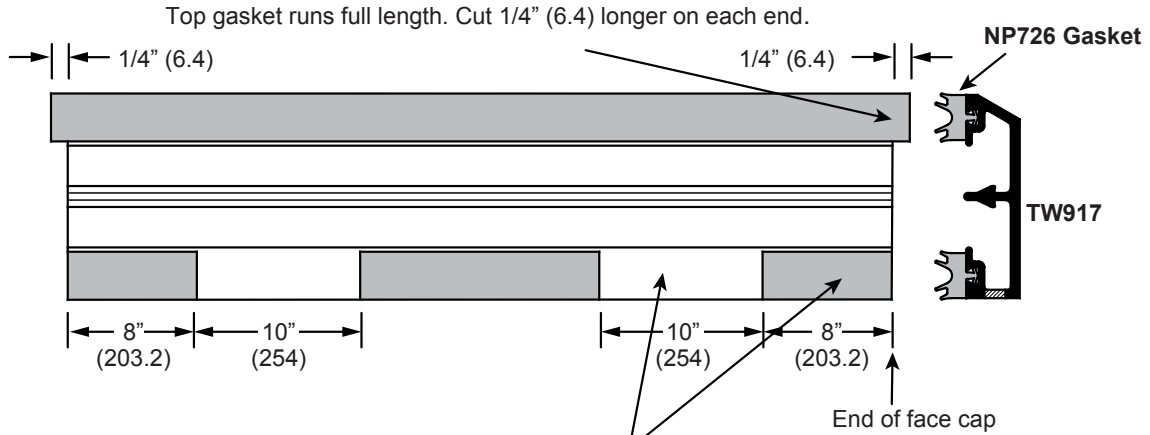

Bottom gasket runs for 8" (203.2) then a 10" (254) gap from each end.

### Vertical Face Plates Only used with jambs

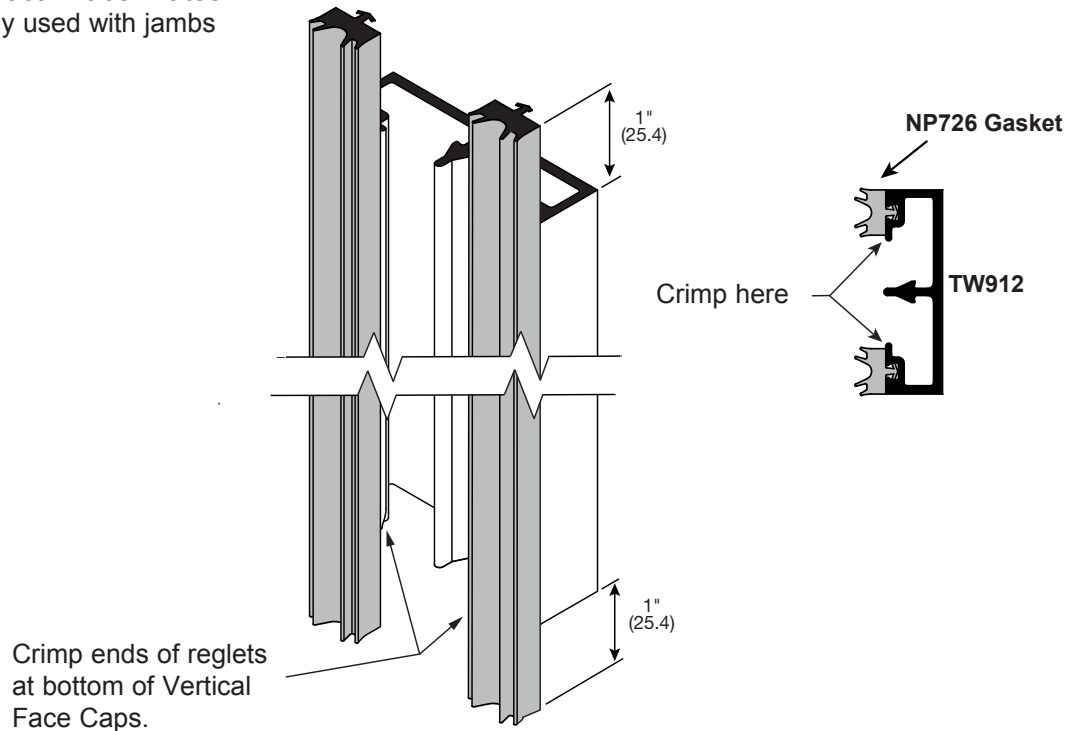

DETAIL O

# ASSEMBLY

## GASKET INSTALLATION (FRAME)

NP716 sponge glazing gasket is used on the interior framing members. Insert push-in gaskets into all back members and face covers. Vertical gaskets on the mullions run through. Horizontal gaskets butt against vertical gaskets and are silicone together.

**NOTE:** All glazing gaskets should be cut 1/8" (3.2) longer per foot of aluminum member to allow for shrinkage.

**NOTE:** All gasket butt joints require silicone adhesive.

Start glazing at bottom and work up.

NOTE: Vertical gaskets stop at intermediate mullions to allow for End Dam and Water Diverter installation. They extend approximately 1/2" (12.7) past edge of Horizontal Mullion.

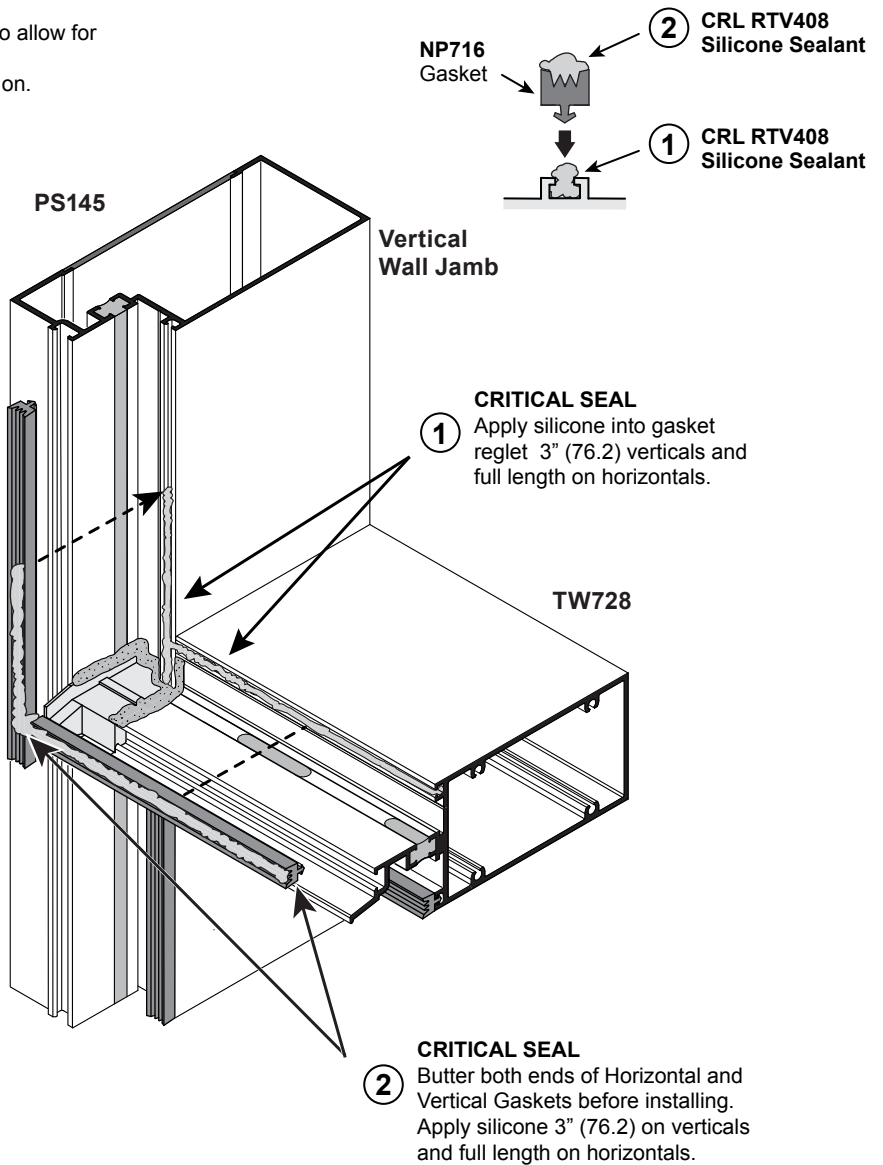
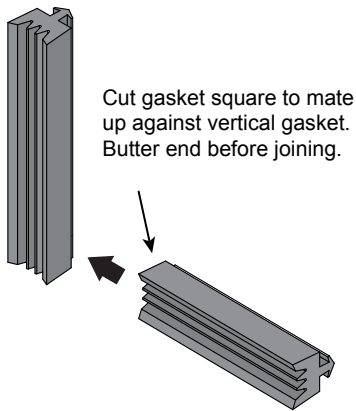
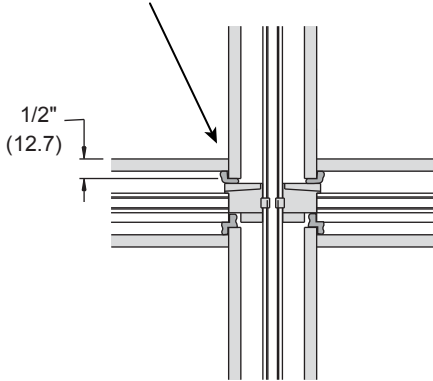

DETAIL P

# ASSEMBLY

## GLAZING END SECTIONS

**GLASS FORMULAS**

Vertical = D.L.O. + 1" (25.4)

Horizontal = D.L.O. + 1-3/8" (34.9)

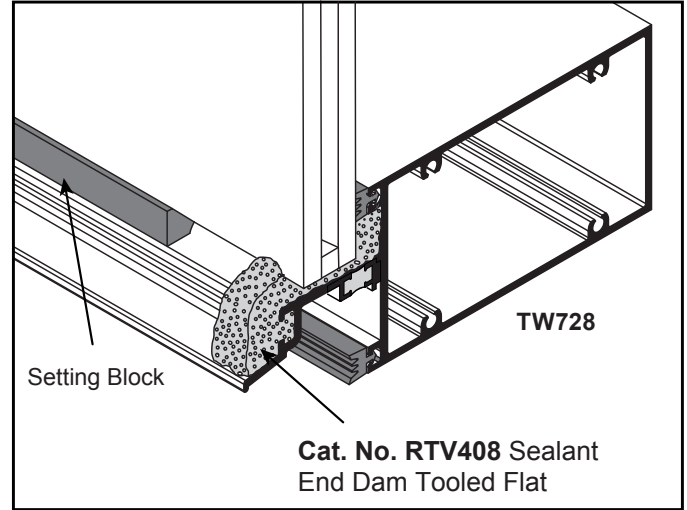
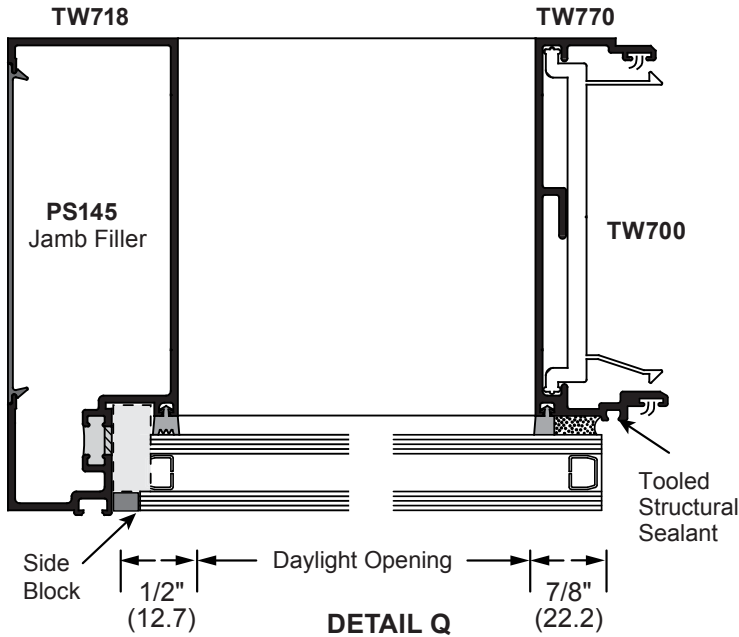

**NOTE:** When setting the glass, the upper and lower glass **MUST BE** in line at all verticals.

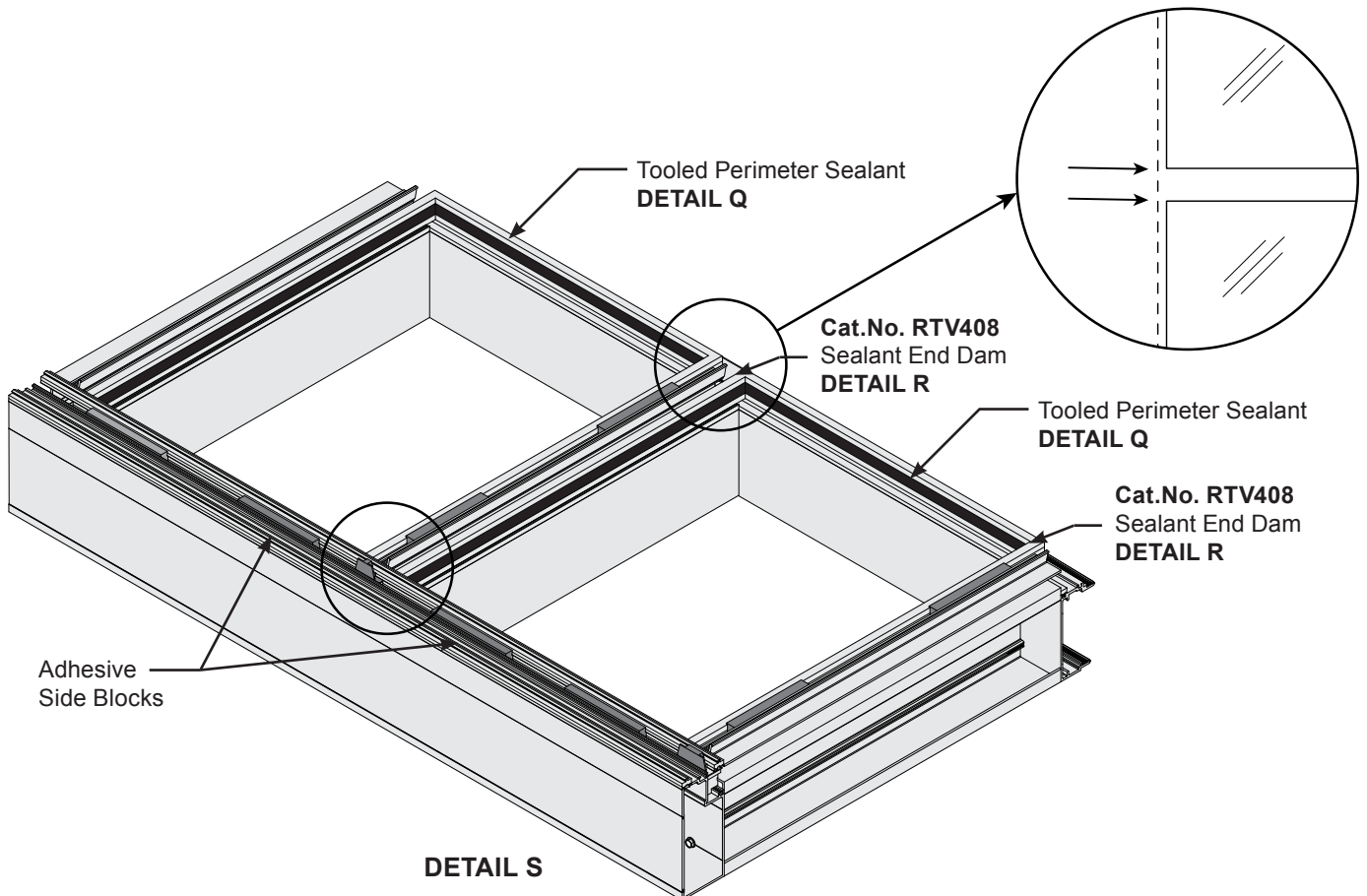



# ASSEMBLY

## GLAZING INTERMEDIATE SECTIONS

**GLASS FORMULAS**  
 Vertical = D.L.O. + 1" (25.4)  
 Horizontal = D.L.O. + 1-3/4" (44.5)

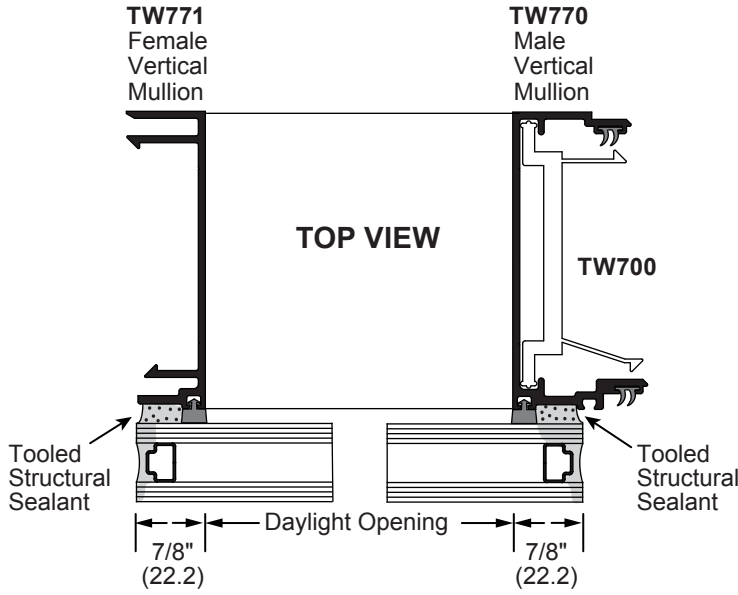

**DETAIL T**

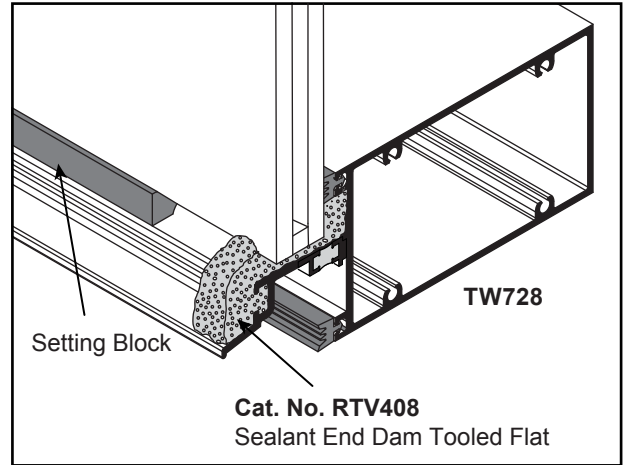

**DETAIL R**

**NOTE:** When setting the glass, the upper and lower glass **MUST BE** in line at all verticals.

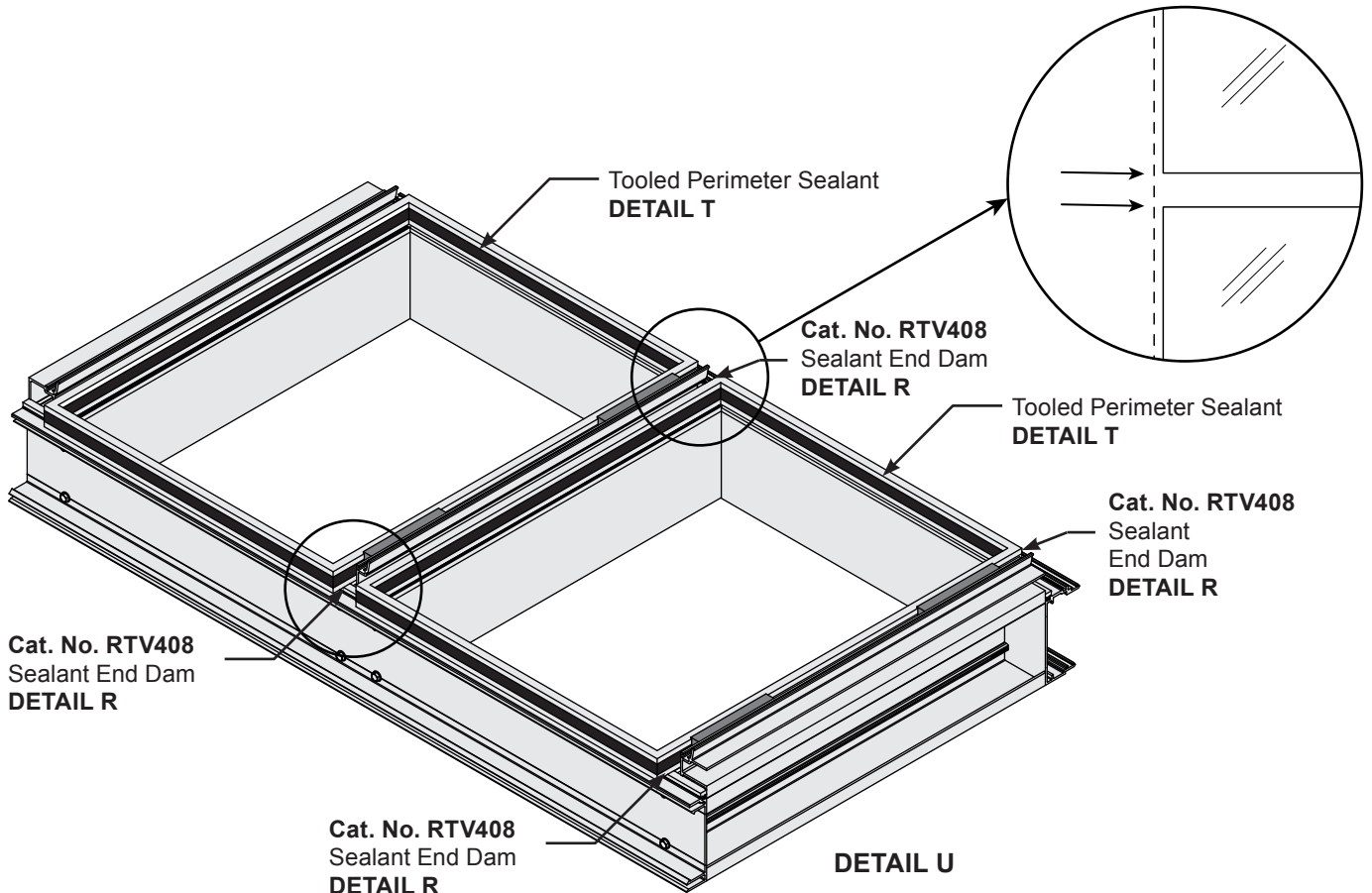

**DETAIL U**

# ASSEMBLY

## INSTALLING FACE CAP CLIPS

Install **NC900** Face Cap Clips using spacing guidelines below. To install Face Cap Clips, twist clockwise. See **DETAIL V**.

### NC900 Face Cap Clip Spacing

Horizontal Members:

2" (50.8) from each end

2" (50.8) from center of each lite

**6" (152.4) on center MAX.**

Vertical Members: (Jambs only)

2" (50.8) from each end

2" (50.8) from center of Horizontal Member

**6" (152.8) on center MAX.**

Splice Joints:

2" (50.8) from each side of Joint

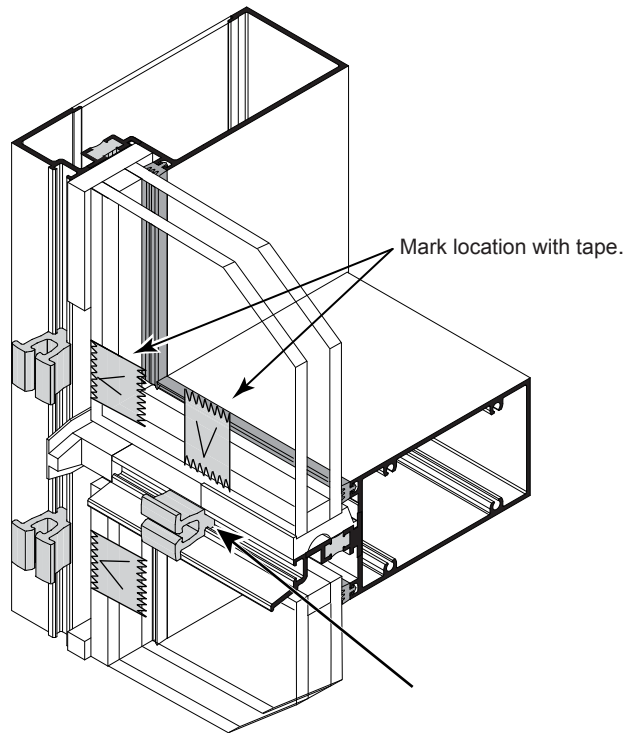

Twist clockwise to install.

DETAIL V

## VERTICAL FACE CAP INSTALLATION

Install Vertical Face Caps on end jambs and door jambs from top to bottom and in between Horizontal Face Caps. Care must be taken to prevent damage of Face Caps during installation. See **DETAIL W**.

Use a 2" x 4" (50.8 x 101.6) piece of wood with **Cat. No. ST57534** CRL 52 oz. Stanley® No Bounce Soft-Face Power Hitter Mallet to engage Face Caps. Use the markers on the glass indicating **NC900** Face Cap Clip locations to engage Face Caps. See **DETAIL X**.

### ONLY HIT COVERS AT FACE CAP CLIP LOCATIONS.

1. Fit vertical Face Cap onto jambs.

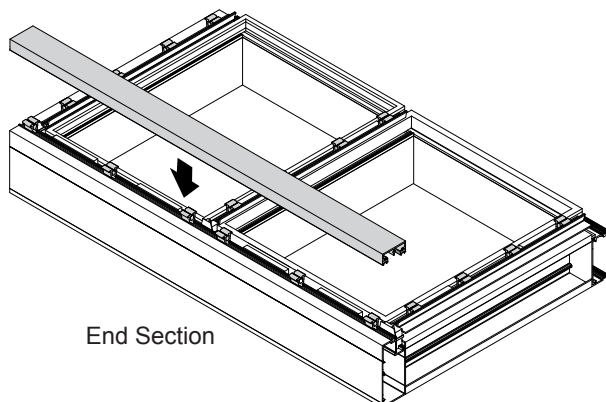

End Section

DETAIL W

2. Use wood block and **Cat. No. ST57534** Mallet to install.

### HIT ONLY AT FACE CAP CLIP LOCATION.

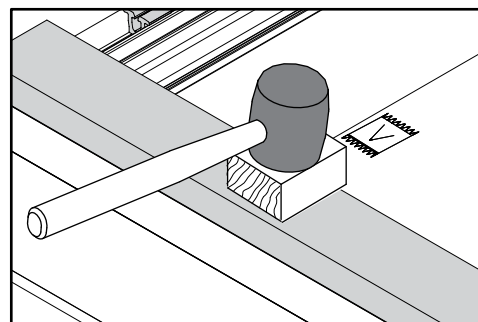

DETAIL X

# ASSEMBLY

## VERTICAL FACE CAP INSTALLATION

Pinning of Vertical Face Caps is required to prevent covers from sliding. Use one screw per cut length nearest the center of the length. Locate the screw so that it rests on the tip edge of the bottom wall of the Horizontal Face Cap, concealed from view.

3. Pin Vertical Face Cap.

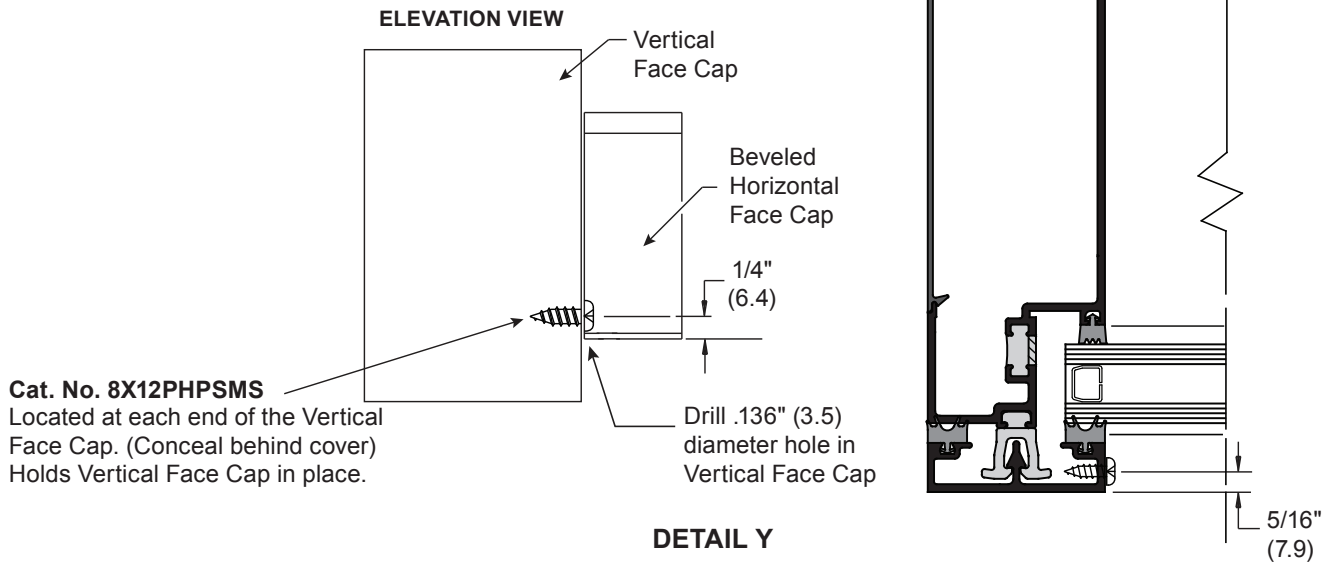

## HORIZONTAL FACE CAP INSTALLATION

Install Horizontal Face Caps. Use same procedure as Vertical Face Caps, striking the covers only at Face Cap clip locations. Always install horizontal face covers with beveled edge on top.

1. Fit Horizontal Face Caps onto horizontal members.

2. Use wood block and **Cat. No. ST57534** Mallet to install.  
**HIT ONLY AT FACE CAP CLIP LOCATION.**

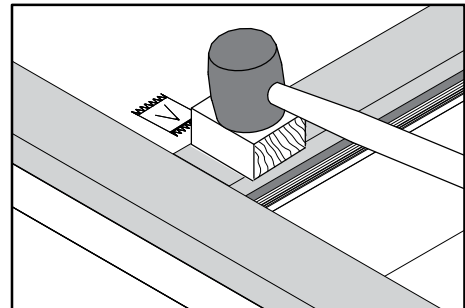
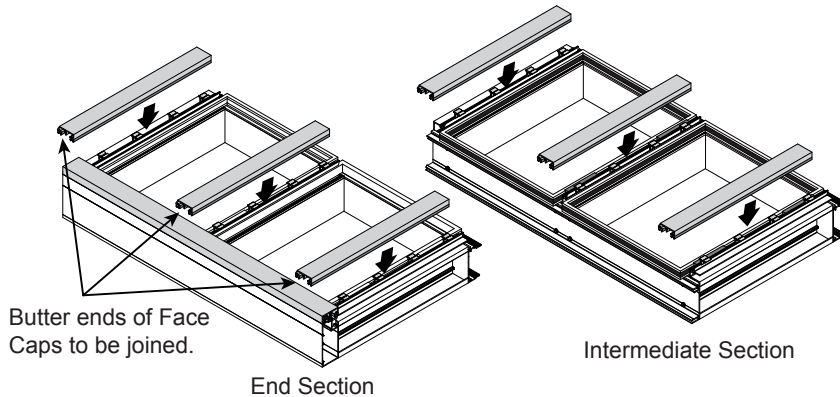

**NOTE:** 1/16" (1.6) MAX gap between Caps at jamb, 1/8" (3.2) MAX at split mullions.

**DETAIL Z**

# INSTALLATION

## SUBSILL END DAMS

Apply end dams to ends of subsill. Do not apply end dams to ends that butt against door jambs.

**NOTE:** Clean all surfaces prior to applying sealants. See sealant manufacturer requirements. TYPICAL AT ALL CONDITIONS

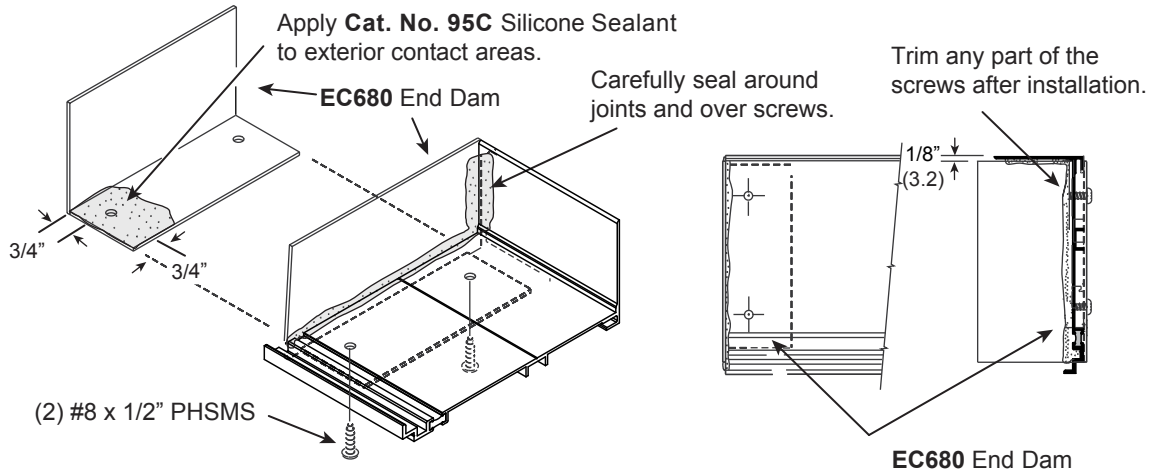

DETAIL AA

## SUBSILL INSTALLATION

Set subsill in place, shimmed as required for leveling and anchor it to structure. Locate fasteners 6" (152.4) each side of verticals and 24" (609.6) O.C. or as required. Holes for fasteners should be elongated laterally to allow for thermal movement. **Pin subsill to structure at one point only per cut length.** (This hole is not elongated). Subsill should be shimmed at fasteners location and underneath verticals. Seal around all joints and over head of fasteners.

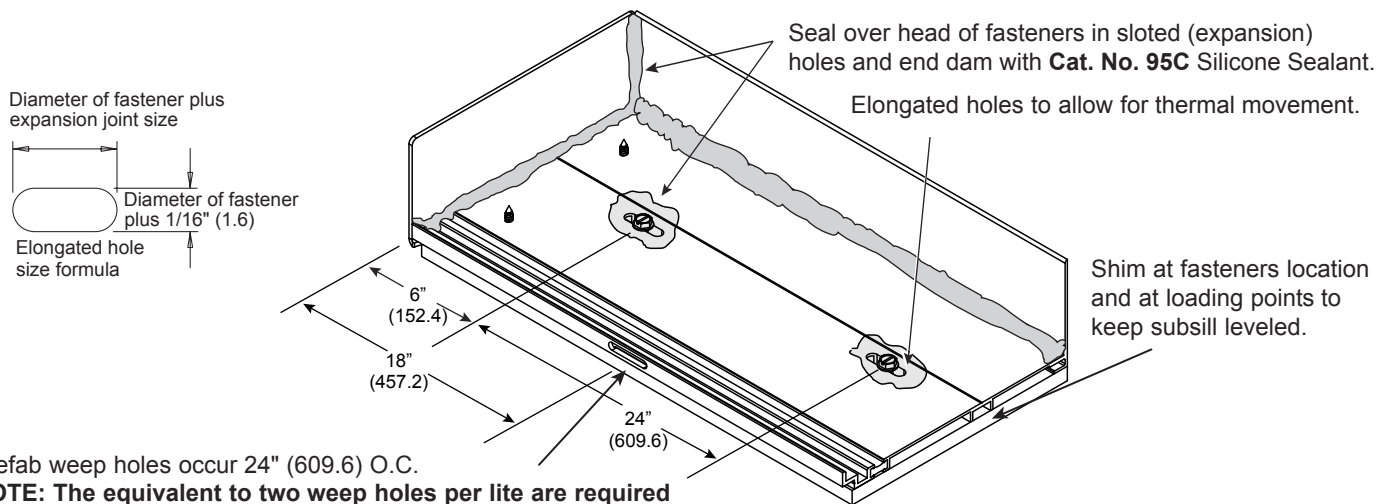

DETAIL BB

# INSTALLATION

## SUBSILL INSTALLATION (CONTINUED)

When end of subsill butts against door jamb it cannot be dammed to allow for sidelite installation. Special care should be taken to control water infiltration at this joint.

Infiltrated water from upper lites must be kept out of door jambs.

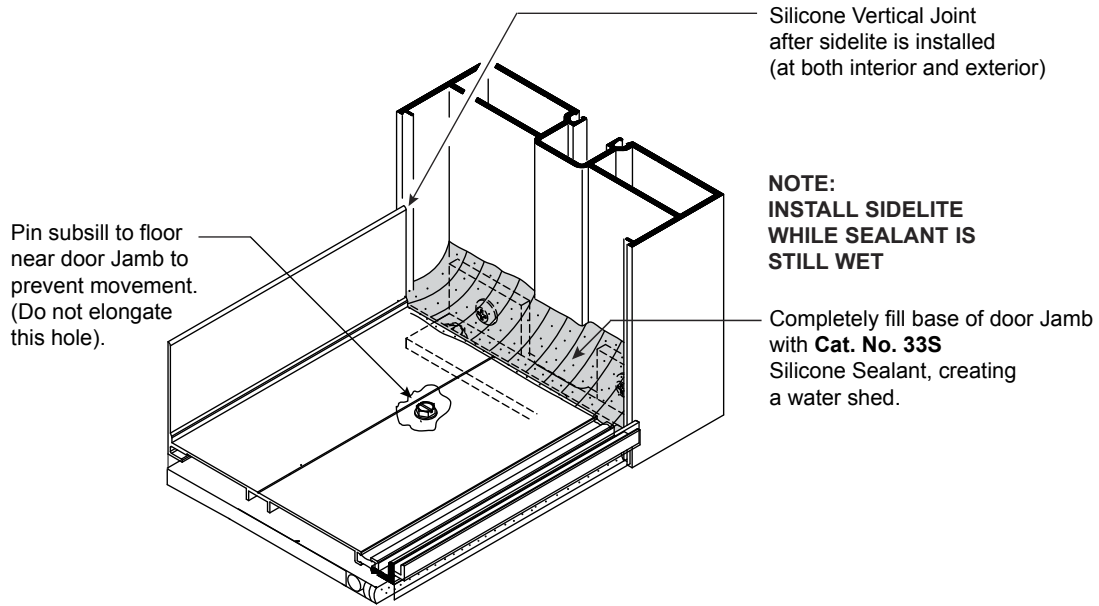

DETAIL CC

Splice subsill as required. Splice sleeves are required at splice joints. Locate splice sleeves near center Daylight Opening.

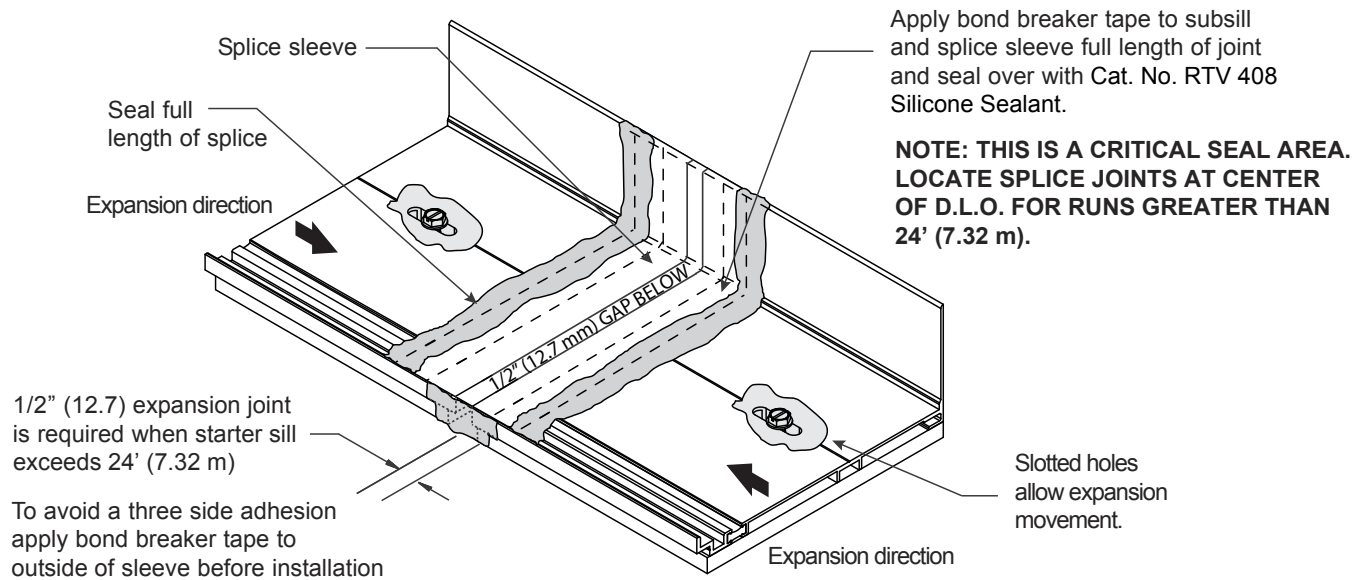

DETAIL DD

# INSTALLATION

## HEAD ANCHORS

Install snap in covers and head anchors. Tape head anchor in place. Mullion caps installed after panels are pushed together.

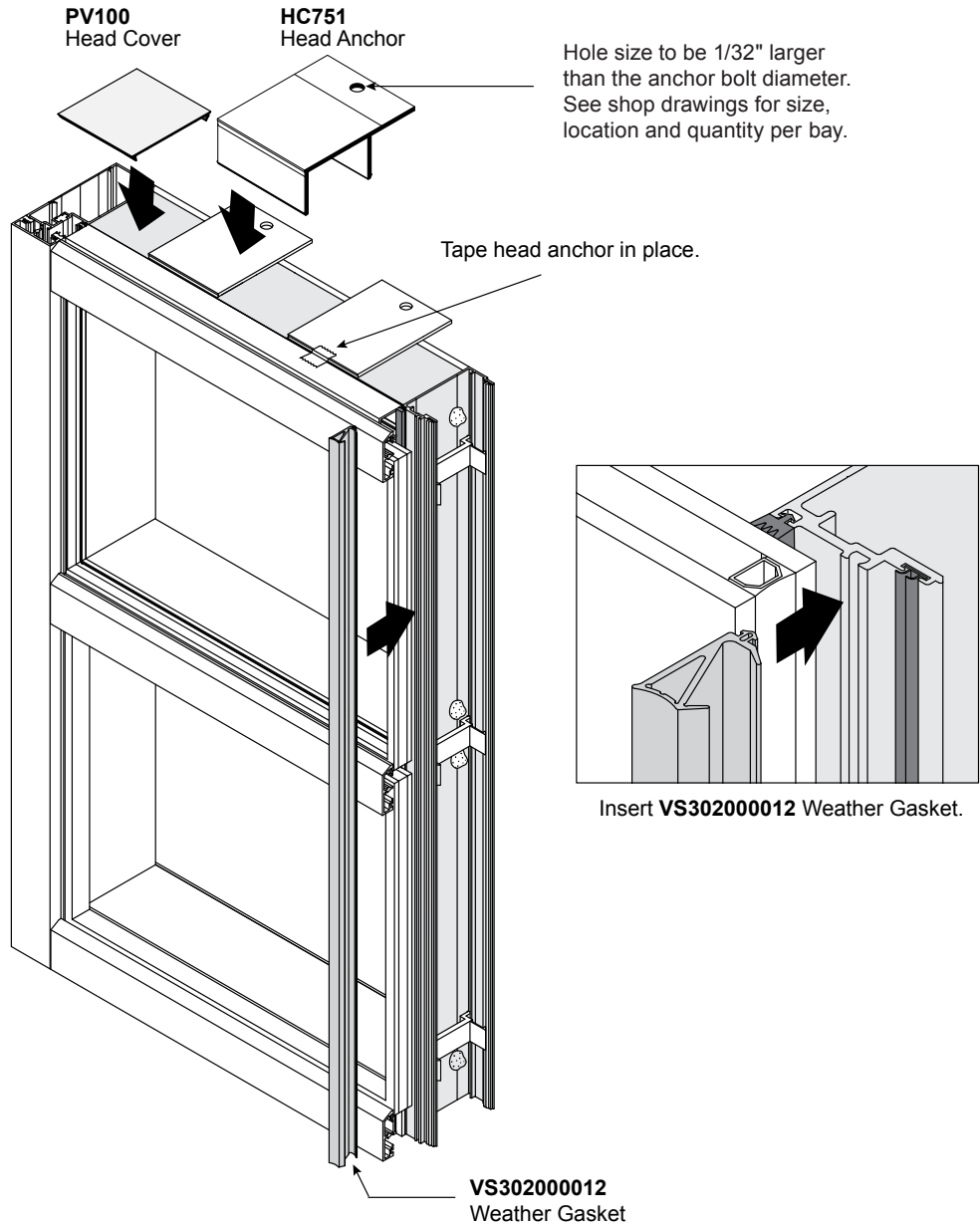

DETAIL EE

# INSTALLATION

## INSERTING THE PANELS

If there are no entrances start installation at wall jamb unit. Apply silicone to end dam contact area. Tuck the panel in from the exterior and then slide up against the end dam.

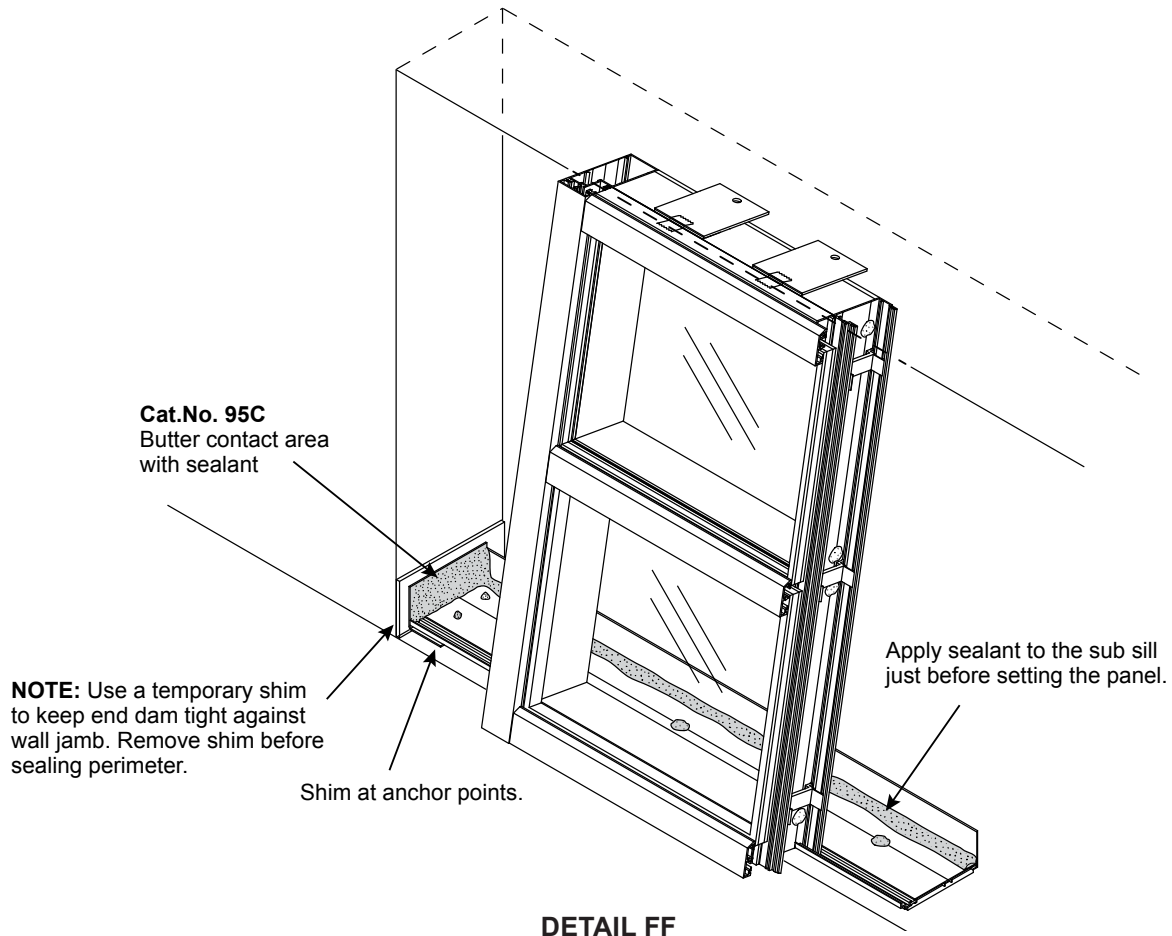

Butter the end of horizontal face plates and top exterior gasket before setting the next panel.

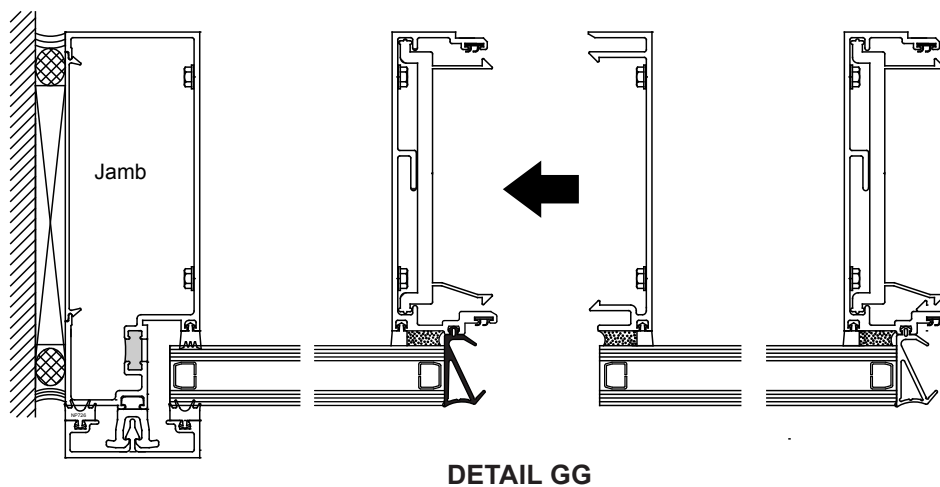

# INSTALLATION

## FASTEN HEAD ANCHORS

Fasten head anchors to the structure using specified fasteners.

**NOTE:** 1/2" (12.7) Minimum clearance between head and structure required to allow for vertical expansion. Anchors may be shimmed if required.

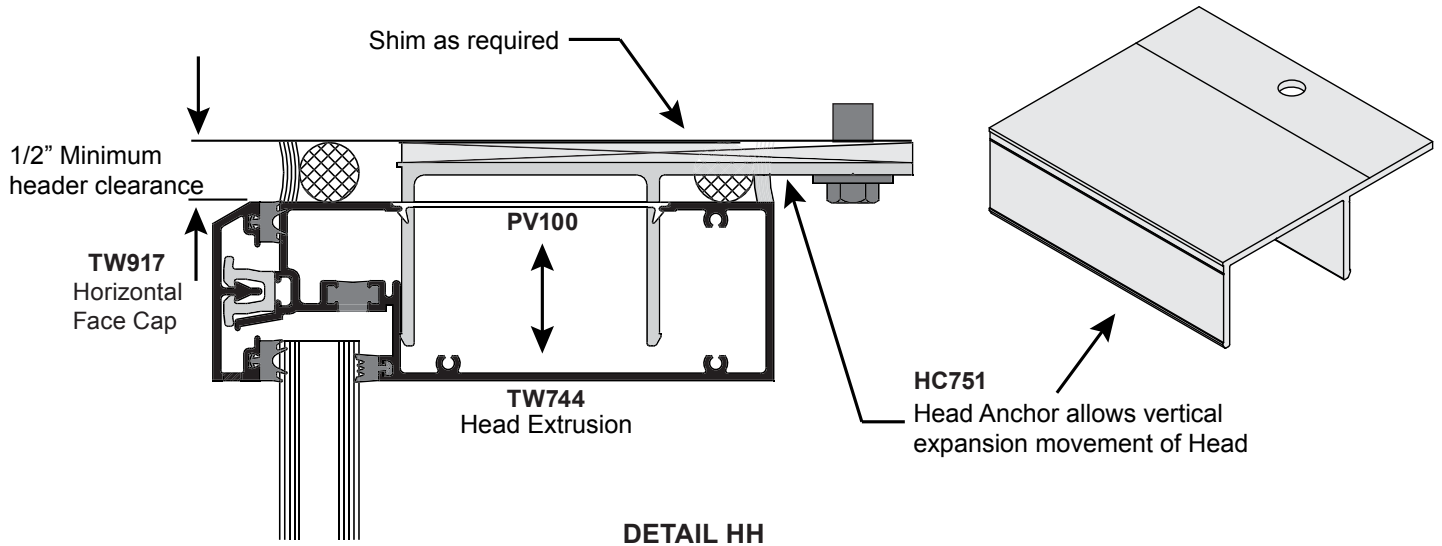

## SEAL END JAMB

The last glazed panel will require a 1" (25.4) gap between the Jamb and the Wall to allow room for inserting it into the subsill. Once the panel is in place. Seal it to the sub sill and wall using **Cat. No. 95C** Silicone Sealant.

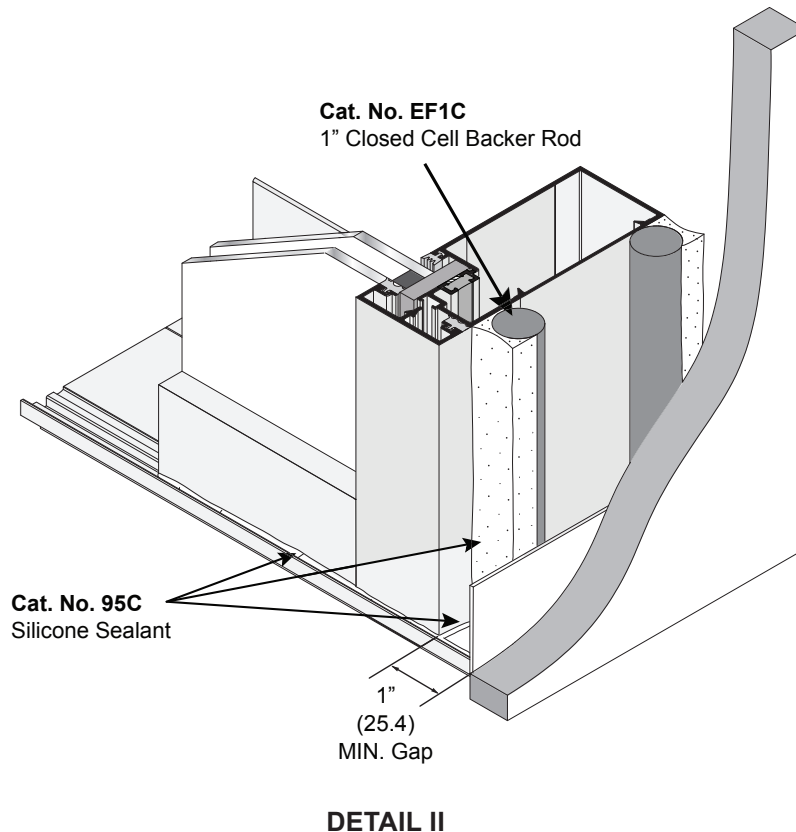



# INSTALLATION

## SEALING THE SUBSILL

Seal joints between panels and subsill at both inside and outside.

**CRITICAL SEAL**

Cat. No. 95C Silicone seal the exterior gap.

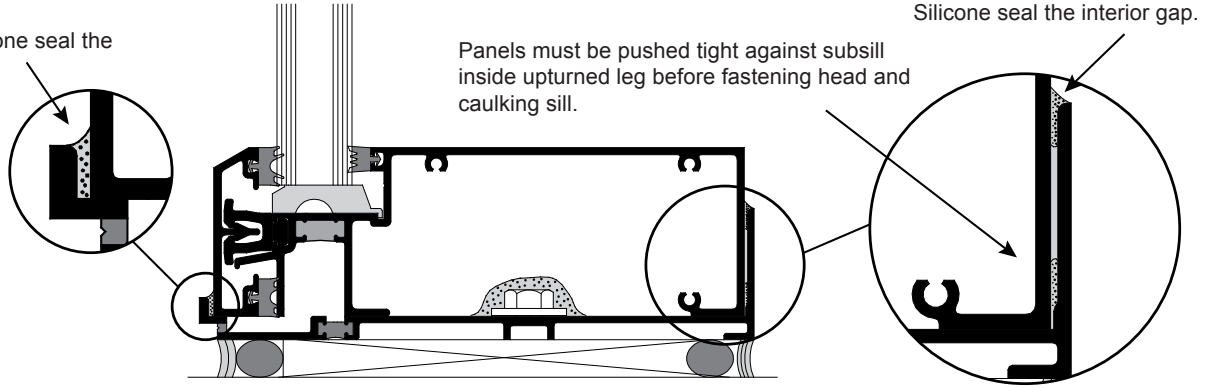

DETAIL JJ

## FINAL SEALING

All exterior perimeter seals must be done as a secondary operation from the exterior. See Detail KK.

Seal interior perimeter at sill and 8" (203.2) up where panels meet. See Detail LL.

Cat. No. 95C  
Exterior  
Perimeter  
Caulking

Jamb

Cat. No. 95C  
Exterior  
Channel  
Caulking

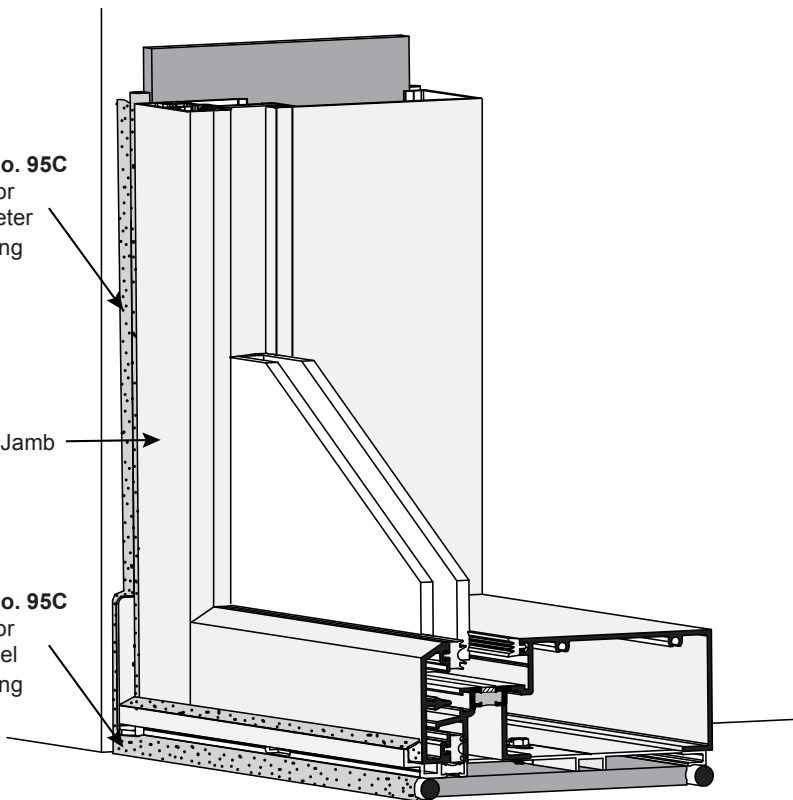

DETAIL KK

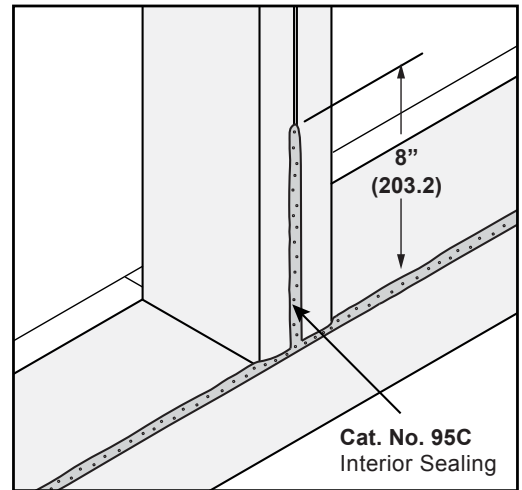

Cat. No. 95C  
Interior Sealing

DETAIL LL

# CAL GUIDE TO SEALANTS

US ALUMINUM

**NOTE: All sealants must be tooled to ensure proper adhesion.**

## WATERPROOFING

- **33S ACETIC CURE SILICONE**

Sill to Subsill, End Dams, Screw Heads, and Threshold to Door Frame Sealing.

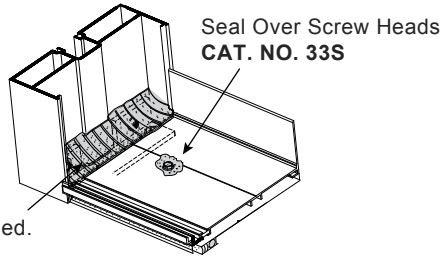

Fill with Sealant to Create a Water Shed.  
CAT. NO. 33S

**NOTE: Not for use near insulating glass units with butyl sealant.**

## EXPANSION

- **95C SILICONE BUILDING SEALANT**

Expansion Joints.

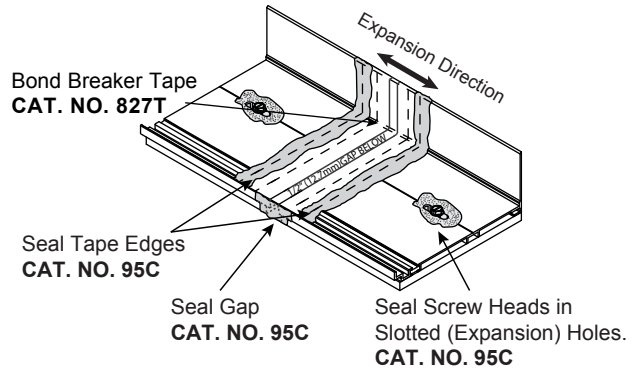

## JOINT ADHESIVE

- **RTV408 NEUTRAL CURE SILICONE**

Small Joints, End Joints and Buttered Surfaces, Water Diverters, End Dams and Reglet Fills.

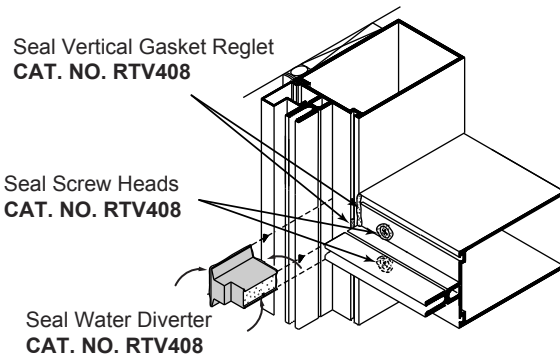
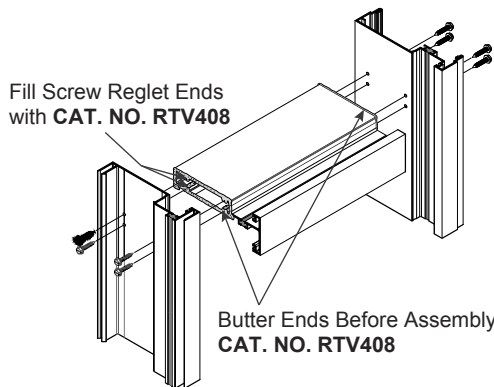

**NOTE: I.G. butyl contact OK.**

## PERIMETER

- **95C SILICONE BUILDING SEALANT (Preferred)**
- **M64 (SMOOTH) MODIFIED POLYURETHANE**
- **M66 (TEXTURED) MODIFIED POLYURETHANE**

Perimeter Seals, Expansion Joints, Sill and Threshold Beds, Concrete, Wood, and Steel Openings.

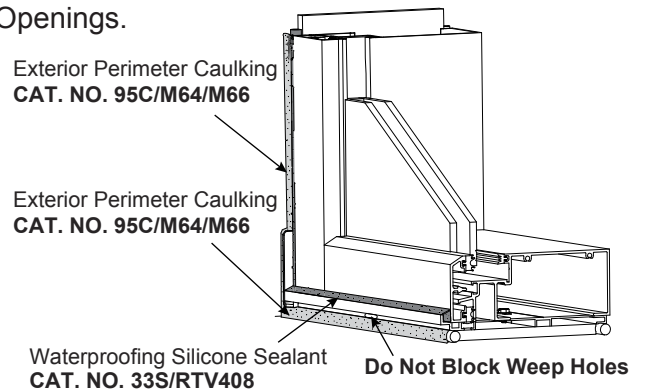

## STRUCTURAL

- **ALL STRUCTURAL SEALANTS REQUIRE TESTING AND APPROVAL.**

Glass-to-Glass or Glass-to-Metal